



Tektronix Logic Analyzer Series Product Specifications

071-1344-00

This document applies to TLA System Software
version 4.3 and above.

www.tektronix.com



071134400

Copyright © Tektronix, Inc. All rights reserved.

Tektronix products are covered by U.S. and foreign patents, issued and pending. Information in this publication supercedes that in all previously published material. Specifications and price change privileges reserved.

Tektronix, Inc., P.O. Box 500, Beaverton, OR 97077

TEKTRONIX and TEK are registered trademarks of Tektronix, Inc.

Specifications and Characteristics

This document lists the specifications for the Tektronix Logic Analyzer family products.

Characteristic Tables

All specifications are guaranteed unless noted *Typical*. Typical characteristics describe typical or average performance and provide useful reference information.

Specifications that are marked with the ✓ symbol are checked directly (or indirectly) in the *Performance Verification* chapter of module's or mainframe service manual.

For mainframes and modules, the performance limits in this specification are valid with these conditions:

- The logic analyzer must be in an environment with temperature, altitude, humidity, and vibration within the operating limits described in these specifications.
- The logic analyzer must have had a warm-up period of at least 30 minutes.

For modules, the performance limits in this specification are valid with these conditions:

- The modules must be installed in a Logic Analyzer Mainframe.
- The module must have been calibrated/adjusted at an ambient temperature between +20 °C and +30 °C.
- The DSO module must have had its signal-path-compensation routine (self calibration or self cal) last executed after at least a 30 minute warm-up period.
- After the warm-up period, the DSO module must have had its signal-path-compensation routine last executed at an ambient temperature within ± 5 °C of the current ambient temperature.

For optimum performance using an external oscilloscope, please consult the documentation for any external oscilloscopes used with your Tektronix Logic Analyzer to determine the warm-up period and signal-path compensation requirements.

Atmospheric Characteristics for the Tektronix Logic Analyzer Family

Table 1 lists the Atmospheric characteristics of all components in the Tektronix Logic Analyzer family.

Table 1: Atmospheric characteristics

| Characteristic | Description |
|--|--|
| Temperature: Operating and nonoperating | <p>Operating (no media in floppy disk drive): +5 °C to +50 °C, 15 °C/hr maximum gradient, non-condensing (derated 1 °C per 1000 ft above 5000 foot altitude)¹</p> <p>Nonoperating (no media in floppy disk drive or CD ROM drive): -20 °C to +60 °C, 15 °C/hr maximum gradient, non-condensing.</p> |
| Relative Humidity: Operating and nonoperating | <p>Operating (no media in floppy disk drive or CD ROM drive): 20% to 80% relative humidity, non-condensing. Maximum wet bulb temperature: +29 °C (derates relative humidity to approximately 22% at +50 °C)²</p> <p>Nonoperating (no media in floppy disk drive or CD ROM drive): 8% to 80% relative humidity, non-condensing. Maximum wet bulb temperature: +29 °C (derates relative humidity to approximately 22% at +50 °C).</p> |
| Altitude: Operating and nonoperating | <p>Operating: To 10,000 ft (3040 m), (derated 1 °C per 1000 ft (305 m) above 5000 ft (1524 m) altitude)</p> <p>Nonoperating: 40,000 ft (12190 m).</p> |

¹ TLA7Axx series module operating temperature is +40 °C maximum.

² TLA7Axx series module operating humidity is 45% at +40 °C.

Certifications and Compliances

Table 2 lists the certifications and compliances of the Tektronix Logic Analyzer family. The certifications and compliances apply to all components of the Tektronix Logic Analyzer family unless noted otherwise.

Table 2: Certifications and compliances

| Category | Standards or description | | | | | | | | | | | | | | | | |
|---|---|--------------------------|---|---------------|--|---------------|---|---------------|--|---------------|---|---------------|---|----------------|---|--------------|----------------------------------|
| EC Declaration of Conformity - EMC | <p>Meets intent of Directive 89/336/EEC for Electromagnetic Compatibility. Compliance was demonstrated to the following specifications as listed in the Official Journal of the European Communities:</p> <table> <tr> <td>EN 61326</td> <td>EMC requirements for Class A electrical equipment for measurement, control and laboratory use.¹</td> </tr> <tr> <td>IEC 61000-4-2</td> <td>Electrostatic discharge immunity (Performance criterion B)</td> </tr> <tr> <td>IEC 61000-4-3</td> <td>RF electromagnetic field immunity (Performance criterion A)</td> </tr> <tr> <td>IEC 61000-4-4</td> <td>Electrical fast transient / burst immunity (Performance criterion B)</td> </tr> <tr> <td>IEC 61000-4-5</td> <td>Power line surge immunity (Performance criterion B)</td> </tr> <tr> <td>IEC 61000-4-6</td> <td>Conducted RF immunity (Performance criterion A)</td> </tr> <tr> <td>IEC 61000-4-11</td> <td>Voltage dips and interruptions immunity (Performance criterion B)</td> </tr> <tr> <td>EN 61000-3-2</td> <td>AC power line harmonic emissions</td> </tr> </table> | EN 61326 | EMC requirements for Class A electrical equipment for measurement, control and laboratory use. ¹ | IEC 61000-4-2 | Electrostatic discharge immunity (Performance criterion B) | IEC 61000-4-3 | RF electromagnetic field immunity (Performance criterion A) | IEC 61000-4-4 | Electrical fast transient / burst immunity (Performance criterion B) | IEC 61000-4-5 | Power line surge immunity (Performance criterion B) | IEC 61000-4-6 | Conducted RF immunity (Performance criterion A) | IEC 61000-4-11 | Voltage dips and interruptions immunity (Performance criterion B) | EN 61000-3-2 | AC power line harmonic emissions |
| EN 61326 | EMC requirements for Class A electrical equipment for measurement, control and laboratory use. ¹ | | | | | | | | | | | | | | | | |
| IEC 61000-4-2 | Electrostatic discharge immunity (Performance criterion B) | | | | | | | | | | | | | | | | |
| IEC 61000-4-3 | RF electromagnetic field immunity (Performance criterion A) | | | | | | | | | | | | | | | | |
| IEC 61000-4-4 | Electrical fast transient / burst immunity (Performance criterion B) | | | | | | | | | | | | | | | | |
| IEC 61000-4-5 | Power line surge immunity (Performance criterion B) | | | | | | | | | | | | | | | | |
| IEC 61000-4-6 | Conducted RF immunity (Performance criterion A) | | | | | | | | | | | | | | | | |
| IEC 61000-4-11 | Voltage dips and interruptions immunity (Performance criterion B) | | | | | | | | | | | | | | | | |
| EN 61000-3-2 | AC power line harmonic emissions | | | | | | | | | | | | | | | | |
| Australia / New Zealand Declaration of Conformity - EMC | <p>Complies with EMC provision of Radiocommunications Act per the following standard(s):</p> <table> <tr> <td>AS/NZS 2064.1/2</td> <td>Industrial, Scientific, and Medical Equipment: 1992</td> </tr> </table> | AS/NZS 2064.1/2 | Industrial, Scientific, and Medical Equipment: 1992 | | | | | | | | | | | | | | |
| AS/NZS 2064.1/2 | Industrial, Scientific, and Medical Equipment: 1992 | | | | | | | | | | | | | | | | |
| EC Declaration of Conformity - Low Voltage | <p>Compliance was demonstrated to the following specification as listed in the Official Journal of the European Communities:</p> <p>Low Voltage Directive 73/23/EEC, amended by 93/68/EEC</p> <table> <tr> <td>EN 61010-1/A2:1995</td> <td>Safety requirements for electrical equipment for measurement control and laboratory use.</td> </tr> </table> | EN 61010-1/A2:1995 | Safety requirements for electrical equipment for measurement control and laboratory use. | | | | | | | | | | | | | | |
| EN 61010-1/A2:1995 | Safety requirements for electrical equipment for measurement control and laboratory use. | | | | | | | | | | | | | | | | |
| U.S. Nationally Recognized Testing Laboratory Listing | <table> <tr> <td>UL3111-1</td> <td>Standard for electrical measuring and test equipment.</td> </tr> </table> | UL3111-1 | Standard for electrical measuring and test equipment. | | | | | | | | | | | | | | |
| UL3111-1 | Standard for electrical measuring and test equipment. | | | | | | | | | | | | | | | | |
| Canadian Certification | <table> <tr> <td>CAN/CSA C22.2 No. 1010.1</td> <td>Safety requirements for electrical equipment for measurement, control, and laboratory use.</td> </tr> </table> | CAN/CSA C22.2 No. 1010.1 | Safety requirements for electrical equipment for measurement, control, and laboratory use. | | | | | | | | | | | | | | |
| CAN/CSA C22.2 No. 1010.1 | Safety requirements for electrical equipment for measurement, control, and laboratory use. | | | | | | | | | | | | | | | | |
| Additional Compliance | <table> <tr> <td>IEC61010-1/A2:1995</td> <td>Safety requirements for electrical equipment for measurement, control, and laboratory use.</td> </tr> </table> | IEC61010-1/A2:1995 | Safety requirements for electrical equipment for measurement, control, and laboratory use. | | | | | | | | | | | | | | |
| IEC61010-1/A2:1995 | Safety requirements for electrical equipment for measurement, control, and laboratory use. | | | | | | | | | | | | | | | | |
| Installation (Overvoltage) Category | <p>Terminals on this product may have different installation (overvoltage) category designations. The installation categories are:</p> <table> <tr> <td>CAT II</td> <td>Local-level mains (wall sockets). Equipment at this level includes appliances, portable tools, and similar products. Equipment is usually cord-connected.</td> </tr> </table> | CAT II | Local-level mains (wall sockets). Equipment at this level includes appliances, portable tools, and similar products. Equipment is usually cord-connected. | | | | | | | | | | | | | | |
| CAT II | Local-level mains (wall sockets). Equipment at this level includes appliances, portable tools, and similar products. Equipment is usually cord-connected. | | | | | | | | | | | | | | | | |

¹ Emissions which exceed the levels required by this standard may occur when this equipment is connected to a test object.

Table 2: Certifications and compliances (Cont.)

| Category | Standards or description |
|---------------------------------|---|
| Pollution Degree | <p>A measure of the contaminates that could occur in the environment around and within a product. Typically the internal environment inside a product is considered to be the same as the external. Products should be used only in the environment for which they are rated.</p> <p>Pollution Degree 2 Normally only dry, nonconductive pollution occurs. Occasionally a temporary conductivity that is caused by condensation must be expected. This location is a typical office/home environment. Temporary condensation occurs only when the product is out of service.</p> |
| Safety Certification Compliance | |
| Equipment Type | Test and measuring |
| Safety Class | Class 1 (as defined in IEC61010-1, Annex H) - grounded product |
| Overvoltage Category | Overvoltage Category II (as defined in IEC61010-1, Annex J) |
| Pollution Degree | Pollution Degree 2 (as defined in IEC61010-1). Note: Rated for indoor use only. |

TLA600 Series Logic Analyzer Specifications

Tables 3 through 17 list the specifications for the TLA600 series logic analyzer.

Table 3: TLA600 input parameters with probes

| Characteristic | Description |
|--|--|
| ✓ Threshold Accuracy | ± 100 mV |
| Threshold range and step size | Settable from +5 V to -2 V in 50 mV steps |
| Threshold channel selection | 16 threshold groups assigned to channels. P6417 and P6418 probes have two threshold settings, one for the clock/qualifier channel and one for the data channels. P6434 probes have four threshold settings, one for each of the clock/qualifier channels and two for the data channels (one per 16 data channels). |
| ✓ Channel-to-channel skew | ≤ 1.6 ns maximum |
| Channel-to-channel skew (Typical) | ≤ 1.0 ns |
| Sample uncertainty | |
| Asynchronous: | Sample period |
| Synchronous: | 500 ps |
| Probe input resistance (Typical) | 20 k Ω |
| Probe input capacitance: P6417, P6434 (Typical) | 2 pF |
| Probe input capacitance: P6418 (Typical) | 1.4 pF data channels 2 pF CLK/Qual channels |
| Minimum slew rate (Typical) | 0.2 V/ns |
| Maximum operating signal | 6.5 V _{p-p} -3.5 V absolute input voltage minimum 6.5 V absolute input voltage maximum |
| Probe overdrive: P6417, P6418 P6434 | ± 250 mV or $\pm 25\%$ of signal swing minimum required beyond threshold, whichever is greater ± 300 mV or $\pm 25\%$ of signal swing minimum required beyond threshold, whichever is greater ± 4 V maximum beyond threshold |
| Maximum nondestructive input signal to probe | ± 15 V |
| Minimum input pulse width signal (single channel) (Typical) | 2 ns |
| Delay time from probe tip to input probe connector (Typical) | 7.33 ns |

Table 4: TLA600 timing latencies

| Characteristic | Description |
|---|---------------|
| System Trigger and External Signal Input Latencies ¹ (Typical) | |
| External System Trigger Input to LA Probe Tip ² | -266 ns |
| External Signal Input to LA Probe Tip via Signal 3, 4 ³ | -212 ns + Clk |
| External Signal Input to LA Probe Tip via Signal 1, 2 ^{3,4} | -208 ns + Clk |
| System Trigger and External Signal Output Latencies (Typical) | |
| LA Probe Tip to External System Trigger Out ⁵ | 376 ns + SMPL |
| LA Probe Tip to External Signal Out via Signal 3, 4 ⁵ | |
| OR function | 366 ns + SMPL |
| AND function | 379 ns + SMPL |
| LA Probe Tip to External Signal Out via Signal 1, 2 ^{4,5} | |
| normal function | 364 ns + SMPL |
| inverted logic on backplane | 364 ns + SMPL |

¹ All system trigger and external signal input latencies are measured from a falling-edge transition (active true low) with signals measured in the wired-OR configuration.

² In the Waveform window, triggers are always marked immediately except when delayed to the first sample. In the Listing window, triggers are always marked on the next sample period following their occurrence.

³ “Clk” represents the time to the next master clock at the destination logic analyzer. In the asynchronous (or internal) clock mode, this represents the delta time to the next sample clock beyond the minimum asynchronous rate of 4 ns. In the synchronous (or external) clock mode, this represents the time to the next master clock generated by the setup of the clocking state machine and the supplied system under test clocks and qualification data.

⁴ Signals 1 and 2 (ECLTRG0, 1) are limited to a “broadcast” mode of operation, where only one source is allowed to drive the signal node at any one time. That single source may be utilized to drive any combination of destinations.

⁵ SMPL represents the time from the event at the probe tip inputs to the next valid data sample. In the Normal Internal clock mode, this represents the delta time to the next sample clock. In the MagniVu Internal clock mode, this represents 500 ps or less. In the External clock mode, this represents the time to the next master clock generated by the setup of the clocking state machine, the system-under-test supplied clocks, and the qualification data.

Table 5: TLA600 external signal interface

| Characteristic | Description |
|--|---|
| System Trigger Input | TTL compatible input via rear panel mounted BNC connectors |
| Input Levels V_{IH} V_{IL} | TTL compatible input $\geq 2.0\text{ V}$ $\leq 0.8\text{ V}$ |
| Input Mode | Falling edge sensitive, latched (active low) |
| Minimum Pulse Width | 12 ns |
| Active Period | Accepts system triggers during valid acquisition periods via real-time gating, resets system trigger input latch between valid acquisition periods |
| Maximum Input Voltage | 0 to +5 V peak |
| External Signal Input | TTL compatible input via rear panel mounted BNC connectors |
| Input Destination | Signal 1, 2, 3, 4 |
| Input Levels V_{IH} V_{IL} | TTL compatible input $\geq 2.0\text{ V}$ $\leq 0.8\text{ V}$ |
| Input Mode | Active (true) low, level sensitive |
| Input Bandwidth ¹ Signal 1, 2 Signal 3, 4 | 50 MHz square wave minimum 10 MHz square wave minimum |
| Active Period | Accepts signals during valid acquisition periods via real-time gating |
| Maximum Input Voltage | 0 to +5 V peak |
| System Trigger Output | TTL compatible output via rear panel mounted BNC connectors |
| Source Mode | Active (true) low, falling edge latched |
| Active Period | Outputs system trigger state during valid acquisition period, resets system trigger output to false state between valid acquisitions |
| Output Levels V_{OH} V_{OL} | 50 Ω back terminated TTL-compatible output $\geq 4\text{ V}$ into open circuit $\geq 2\text{ V}$ into 50 Ω to ground $\leq 0.7\text{ V}$ sinking 10 mA |
| Output Protection | Short-circuit protected (to ground) |
| External Signal Output | TTL compatible outputs via rear panel mounted BNC connectors |
| Source Selection | Signal 1, 2, 3, 4, or 10 MHz clock |
| Output Modes Level Sensitive | User definable Active (true) low or active (true) high |
| Output Levels V_{OH} V_{OL} | 50 Ohm back terminated TTL output $\geq 4\text{ V}$ into open circuit $\geq 2\text{ V}$ into 50 Ω to ground $\leq 0.7\text{ V}$ sinking 10 mA |

Table 5: TLA600 external signal interface (Cont.)

| Characteristic | Description |
|---|---|
| Output Bandwidth ² Signal 1, 2 Signal 3, 4 | 50 MHz square wave minimum 10 MHz square wave minimum |
| Active Period | Outputs signals during valid acquisition periods, resets signals to false state between valid acquisitions Outputs 10 MHz clock continuously |
| Output Protection | Short-circuit protected (to ground) |

¹ The Input Bandwidth specification only applies to signals to the modules; it does not apply to signals applied to the External Signal Input and sent back to the External Signal Output.

² The Output Bandwidth specification only applies to signals from the modules; it does not apply to signals applied to the External Signal Input and sent back to the External Signal Output.

Table 6: TLA600 channel width and depth

| Characteristic | Description | |
|--------------------------|--------------------------------|------------------------------------|
| Number of channels | Product | Channels |
| | TLA601, TLA611, TLA621 | 32 data and 2 clock |
| | TLA602, TLA612, TLA622 | 64 data and 4 clock |
| | TLA603, TLA613, TLA623 | 96 data, 4 clock, and 2 qualifier |
| Acquisition memory depth | Product | Memory depth |
| | TLA601, TLA602, TLA603, TLA604 | 64 K or 256 K samples ¹ |
| | TLA611, TLA612, TLA613, TLA614 | 64 K or 256 K samples ¹ |
| | TLA621, TLA622, TLA623, TLA624 | 1 M samples |

¹ PowerFlex options

Table 7: TLA600 clocking

| Characteristic | Description | |
|---|---|--------------------|
| Asynchronous clocking | | |
| ✓ Internal sampling period ¹ | 4 ns to 50 ms in a 1-2-5 sequence 2 ns in 2x Clocking mode | |
| ✓ Minimum recognizable word ² (across all channels) | Channel-to-channel skew + sample uncertainty Example: for a P6417, P6418, or P6434 Probe and a 4 ns sample period = 1.6 ns + 4 ns = 5.6 ns | |
| Synchronous clocking | | |
| Number of clock channels ³ | Product | Clock channels |
| | TLA601, TLA611, TLA621 | 2 |
| | TLA602, TLA612, TLA622 | 4 |
| | TLA603, TLA613, TLA623 TLA604, TLA614, TLA624 | 4 4 |
| Number of qualifier channels ⁵ | Product | Qualifier channels |
| | TLA601, TLA611, TLA621 | 0 |
| | TLA602, TLA612, TLA622 | 0 |
| | TLA603, TLA613, TLA623 TLA604, TLA614, TLA624 | 2 4 |
| ✓ Setup and hold window size (data and qualifiers) | Maximum window size = Maximum channel-to-channel skew + (2 x sample uncertainty) + 0.4 ns Maximum setup time = User interface setup time + 0.8 ns Maximum hold time = User interface hold time + 0.2 ns Examples: for a P6417 or a P6418 probe and user interface setup and hold of 2.0/0.0 typical: Maximum window size = 1.6 ns + (2 x 500 ps) + 0.4ns = 3.0 ns Maximum setup time = 2.0 ns + 0.8 ns = 2.8 ns Maximum hold time = 0.0 ns + 0.2 ns = 0.2ns | |
| Setup and hold window size (data and qualifiers) (Typical) | Channel-to-channel skew (<i>typical</i>) + (2 x sample uncertainty) Example: for P6417 or P6418 Probe = 1 ns + (2 x 500 ps) = 2 ns | |
| Setup and hold window range | For each channel, the setup and hold window can be moved from +8.5 ns (Ts) to -7.0 ns (Ts) in 0.5 ns steps (setup time). Hold time follows the setup time by the setup and hold window size. | |
| ✓ Maximum synchronous clock rate ⁴ | 200 MHz in full speed mode (5 ns minimum between active clock edges) 100 MHz (10 ns minimum between active clock edges) | |
| Demux clocking | | |
| TLA603, TLA613, TLA623 TLA604, TLA614, TLA624 | Channels multiplex as follows: A3(7:0) to D3(7:0) A2(7:0) to D2(7:0) A1(7:0) to D1(7:0) A0(7:0) to D0(7:0) | |

Table 7: TLA600 clocking (Cont.)

| Characteristic | Description |
|--|--|
| TLA601, TLA611, TLA621 TLA602, TLA612, TLA622 | Channels multiplex as follows: A3(7:0) to C3(7:0) A2(7:0) to C2(7:0) A1(7:0) to D1(7:0) TLA602, TLA612, TLA622 A0(7:0) to D0(7:0) TLA602, TLA612, TLA622 |
| Time between DeMux clock edges ⁴ (Typical) | 5 ns minimum between Demux clock edges in full-speed mode 10 ns minimum between Demux clock edges in half-speed mode |
| Time between DeMux store clock edges ⁴ (Typical) | 10 ns minimum between Demux master clock edges in full-speed mode 20 ns minimum between Demux master clock edges in half-speed mode |
| Data Rate ⁴ (Typical) | 400 MHz (200 MHz option required) half channel. (Requires channels to be multiplexed.) These multiplexed channels double the memory depth. |
| Clocking state machine | |
| Pipeline delays | Each channel can be programmed with a pipeline delay of 0 through 3 active clock edges. |

- 1 **It is possible to use storage control and only store data when it has changed (transitional storage).**
- 2 **Applies to asynchronous clocking only. Setup and hold window specification applies to synchronous clocking only.**
- 3 **Any or all of the clock channels may be enabled. For an enabled clock channel, either the rising, falling, or both edges can be selected as the active clock edges. The clock channels are stored.**
- 4 **Full and half speed modes are controlled by PowerFlex options and upgrade kits.**
- 5 **All qualifier channels are stored. For custom clocking there are an additional 4 qualifier channels on C2 3:0 regardless of channel width.**

Table 8: TLA600 trigger system

| Characteristic | Description | | | | | | | | | | |
|--------------------------------|---|---------------------|---------------------|---------------------|--------------------|---------------------|---------------------|--------------------|---------------------|--------------------|---------------------|
| Triggering Resources | | | | | | | | | | | |
| Word/Range recognizers | 16 word recognizers. The word recognizers can be combined to form full width, double bounded, range recognizers. The following selections are available: <table style="width: 100%; border: none;"> <tr> <td style="width: 50%;">16 word recognizers</td> <td style="width: 50%;">0 range recognizers</td> </tr> <tr> <td>13 word recognizers</td> <td>1 range recognizer</td> </tr> <tr> <td>10 word recognizers</td> <td>2 range recognizers</td> </tr> <tr> <td>7 word recognizers</td> <td>3 range recognizers</td> </tr> <tr> <td>4 word recognizers</td> <td>4 range recognizers</td> </tr> </table> | 16 word recognizers | 0 range recognizers | 13 word recognizers | 1 range recognizer | 10 word recognizers | 2 range recognizers | 7 word recognizers | 3 range recognizers | 4 word recognizers | 4 range recognizers |
| 16 word recognizers | 0 range recognizers | | | | | | | | | | |
| 13 word recognizers | 1 range recognizer | | | | | | | | | | |
| 10 word recognizers | 2 range recognizers | | | | | | | | | | |
| 7 word recognizers | 3 range recognizers | | | | | | | | | | |
| 4 word recognizers | 4 range recognizers | | | | | | | | | | |
| Range recognizer channel order | From most-significant probe group to least-significant probe group: C3 C2 C1 C0 E3 E2 E1 E0 A3 A2 D3 D2 A1 A0 D1 D0 Q3 Q2 Q1 Q0 CK3 CK2 CK1 CK0 Missing channels for modules with fewer than 136 channels are omitted. | | | | | | | | | | |
| Glitch detector ^{1,2} | Each channel group can be enabled to detect a glitch | | | | | | | | | | |

Table 8: TLA600 trigger system (Cont.)

| Characteristic | Description |
|--|---|
| Minimum detectable glitch pulse width (Typical) | 2.0 ns (single channel with P6417, P6418, or a P6434 probe) |
| Setup and hold violation detector ^{1,3} | Each channel can be enabled to detect a setup and hold violation. The range is from 8 ns before the clock edge to 8 ns after the clock edge. The range can be selected in 0.5 ns increments. The setup and hold violation of each window can be individually programmed. |
| Transition detector ¹ | Each channel group can be enabled or disabled to detect a transition between the current valid data sample and the previous valid data sample. This mode can be used to create transitional storage selections where all channels are enabled. |
| Counter/Timers | 2 counter/timers, 51 bits wide, can be clocked up to 250 MHz. Maximum count is 2^{51} . Maximum time is 9.007×10^6 seconds or 104 days. Counters and timers can be set, reset, or tested and have zero reset latency. |
| External Signal In ¹ | A backplane input signal |
| External Trigger In | A backplane input signal that causes the main acquisition and the MagniVu acquisition to trigger if they are not already triggered |
| Active trigger resources | 16 maximum (excluding counter/timers) Word recognizers are traded off one-by-one as External Signal In, glitch detection, setup and hold detection, or transition detection resources are added. |
| Trigger States | 16 |
| ✓ Trigger State sequence rate | Same rate as valid data samples received, 250 MHz maximum |
| Trigger Machine Actions | |
| Main acquisition trigger | Triggers the main acquisition memory |
| Main trigger position | Trigger position is programmable to any data sample (4 ns boundaries) |
| MagniVu™ acquisition trigger | Triggering of MagniV memory is controlled by the main acquisition trigger |
| MagniVu™ trigger position | The MagniV trigger position is programmable within 4 ns boundaries and separate from the main acquisition memory trigger position. |
| Increment counter | Either of the two counter/timers used as counters can be increased. |
| Start/Stop timer | Either of the two counter/timers used as timers can be started or stopped. |
| Reset counter/timer | Either of the two counter/timers can be reset. When a counter/timer is used as a timer and is reset, the timer continues from the started or stopped state that it was in prior to the reset. |
| Signal out | A signal sent to the backplane to be used by other instruments |
| Trigger out | A trigger out signal sent to the backplane to trigger other instruments |

Table 8: TLA600 trigger system (Cont.)

| Characteristic | Description |
|----------------------------------|--|
| Storage Control | |
| Global storage | <p>Storage is allowed only when a specific condition is met. This condition can use any of the trigger machine resources except for the counter/timers. Storage commands defined in the current trigger state will override the global storage control.</p> <p>Global storage can be used to start the acquisition with storage initially turned on (default) or turned off.</p> |
| By event | Storage can be turned on or off; only the current sample can be stored. The event storage control overrides any global storage commands. |
| Block storage | <p>When enabled, 31 samples are stored before and after the valid sample.</p> <p>Not allowed when glitch storage or setup and hold violation is enabled.</p> |
| Glitch violation storage | The acquisition memory can be enabled to store glitch violation information with each data sample when asynchronous clocking is used. The probe data storage size is reduced by one half (the other half holds the violation information). The fastest asynchronous clocking rate is reduced to 10 ns. |
| Setup and hold violation storage | The acquisition memory can be enabled to store setup and hold violation information with each data sample when synchronous clocking is used. The probe data storage size is reduced by one half (the other half holds the violation information). The maximum clock rate is reduced by half. |

- ¹ **Each use of External Signal In, glitch detector, setup and hold violation detector, or transition detector requires a trade-off of one word recognizer resource.**
- ² **Any glitch is subject to pulse width variation of up to the channel-to-channel skew specification + 0.5 ns.**
- ³ **Any setup value is subject to variation of up to 1.8 ns; any hold value is subject to variation of up to 1.2 ns.**

Table 9: TLA600 MagniVu™ feature

| Characteristic | Description |
|-------------------------|---|
| MagniVu memory depth | 2016 samples per channel |
| MagniVu sampling period | Data is asynchronously sampled and stored every 500 ps in a separate high resolution memory. There are no clocking options. |

Table 10: TLA600 Data handling

| Characteristic | Description |
|---|---|
| Nonvolatile memory retention time (Typical) | Battery is integral to the NVRAM. Battery life is > 10 years. |

Table 11: TLA600 internal controller

| Characteristic | Description |
|---|--|
| Operating System | Microsoft Windows |
| Microprocessor | Intel Celeron, 566 MHz |
| Main Memory | SDRAM |
| Style | 168 pin DIMM, 2 Sockets |
| Speed | 100 MHz |
| Installed Configurations | Minimum 256 MB loaded in one socket Maximum 512 MB with both sockets loaded |
| Real-Time Clock and CMOS Setups, Plug & Play NVRAM Retention Time | Battery life is typically > 3 years when the logic analyzer is not connected to line voltage. When connected to line voltage the life of the battery is extended. Lithium battery, CR3032 |
| Hard Disk Drive | Standard PC compatible IDE (Integrated Device Electronics) hard disk drive residing on an EIDE interface. |
| Size | Minimum 10 GByte Maximum 30 GByte Continually subject to change due to the fast-moving PC component environment. These storage capacities valid at product introduction. |
| CD-RW Drive | Standard PC compatible IDE (Integrated Device Electronics) 24x-10x-40x CD-RW drive residing on an EIDE interface. Continually subject to change due to the fast-moving PC component environment. |
| Floppy Disk Drive | Standard 3.5 inch 1.44-MB PC compatible high-density, double-sided floppy disk drive. |

Table 12: TLA600 display system

| Characteristic | Description | | | | | | | | | | |
|--|---|---------------------|--------|-----------|-------------------|-----------|-------------------|------------|----------------|-------------|----------------|
| Classification | Standard PC graphics accelerator technology (bitBLT-based); capable of supporting both internal color LCD display and external color SVGA/XGA monitor | | | | | | | | | | |
| Display Memory Size | DRAM-based frame-buffer memory 2 MB | | | | | | | | | | |
| Display Selection | Both front panel and external displays can be used simultaneously, each with independent resolutions. Supports Windows dual-monitor capability. | | | | | | | | | | |
| External Display Drive Display Size | One SVGA/XGA-compatible analog output port Selected via Windows Plug and Play support for DDC1 and DDC2 A and B <table border="0"> <tr> <td>Resolution (Pixels)</td> <td>Colors</td> </tr> <tr> <td>640 x 480</td> <td>256, 64 K, 16.8 M</td> </tr> <tr> <td>800 x 600</td> <td>256, 64 K, 16.8 M</td> </tr> <tr> <td>1024 x 768</td> <td>256, 64 K, 8 M</td> </tr> <tr> <td>1280 x 1024</td> <td>256, 64 K, 8 M</td> </tr> </table> | Resolution (Pixels) | Colors | 640 x 480 | 256, 64 K, 16.8 M | 800 x 600 | 256, 64 K, 16.8 M | 1024 x 768 | 256, 64 K, 8 M | 1280 x 1024 | 256, 64 K, 8 M |
| Resolution (Pixels) | Colors | | | | | | | | | | |
| 640 x 480 | 256, 64 K, 16.8 M | | | | | | | | | | |
| 800 x 600 | 256, 64 K, 16.8 M | | | | | | | | | | |
| 1024 x 768 | 256, 64 K, 8 M | | | | | | | | | | |
| 1280 x 1024 | 256, 64 K, 8 M | | | | | | | | | | |
| Internal Display Classification | Thin Film Transistor (TFT) 10.4 inch active-matrix color LCD display; CCFL backlight; intensity controllable via software | | | | | | | | | | |
| Resolution | 800 x 600 pixels | | | | | | | | | | |
| Color Scale | 262,144 colors (6-bit RGB) | | | | | | | | | | |

Table 13: TLA600 front-panel interface

| Characteristic | Description |
|------------------------|---|
| QWERTY Keypad | ASCII keypad to support naming of files, traces, and keyboard equivalents of pointing device inputs for menus |
| Special Function Knobs | Various functions |

Table 14: TLA600 rear-panel interface

| Characteristic | Description |
|----------------------------------|---|
| Parallel Interface Port (LPT) | 36-pin high-density connector supports standard Centronics mode, Enhanced Parallel Port (EPP), or Microsoft high-speed mode (ECP) |
| Serial Interface Port (COM 1) | 9-pin male sub-D connector to support RS-232 serial port |
| Single USB Ports | One USB (Universal Serial Bus) compliant port |
| SVGA Output Port (SVGA OUT) | 15-pin sub-D SVGA connector |
| Mouse Port | PS/2 compatible mouse port utilizing a mini DIN connector |
| Keyboard Port | PS/2 compatible keyboard port utilizing a mini DIN connector |
| Type I and II PC Card Port | Standard Type I and II PC-compatible PC card slot |
| Type I, II, and III PC Card Port | Standard Type I, II, and III PC-compatible PC card slot |

Table 15: TLA600 AC power source

| Characteristic | Description |
|--|---|
| Source Voltage and Frequency | 90-250 V _{RMS} , 45-66 Hz, continuous range CAT II 100-132 V _{RMS} , 360-440 Hz, continuous range CAT II |
| Fuse Rating | |
| 90 V - 132 V Operation (2 required) | UL198/CSA C22.2 0.25 in × 1.25 in, Fast Blow, 8 A, 250 V |
| 90 V - 250 V Operation (2 required) | IEC 127/Sheet 1 5 mm × 20 mm, Fast Blow, 6.3 A, 250 V |
| Maximum Power Consumption | 600 Watts line power maximum |
| Steady-State Input Current | 6 A _{RMS} maximum |
| Inrush Surge Current | 70 A maximum |
| Power Factor Correction | Yes |
| On/Standby Switch and Indicator | Front Panel On/Standby switch, with indicator. The power cord provides main power disconnect. |

Table 16: TLA600 cooling

| Characteristic | Description |
|-------------------|---|
| Cooling System | Forced air circulation (negative pressurization) utilizing six fans operating in parallel |
| Cooling Clearance | 2 in (51 mm), sides and rear; unit should be operated on a flat, unobstructed surface |

Table 17: TLA600 mechanical characteristics

| Characteristic | Description |
|---------------------------------------|--|
| Overall Dimensions | See Figure 1 for overall chassis dimensions |
| Weight | Includes empty accessory pouch and front cover |
| TLA614, TLA624, TLA613, and TLA623 | 18.1 Kg (40 lbs) |
| TLA612, TLA622, TLA611, and TLA621 | 18 Kg (39.75 lbs) |
| TLA604 and TLA603 | 17.6 Kg (38.75 lbs) |
| TLA602 and TLA601 | 17.5 Kg (38.5 lbs) |

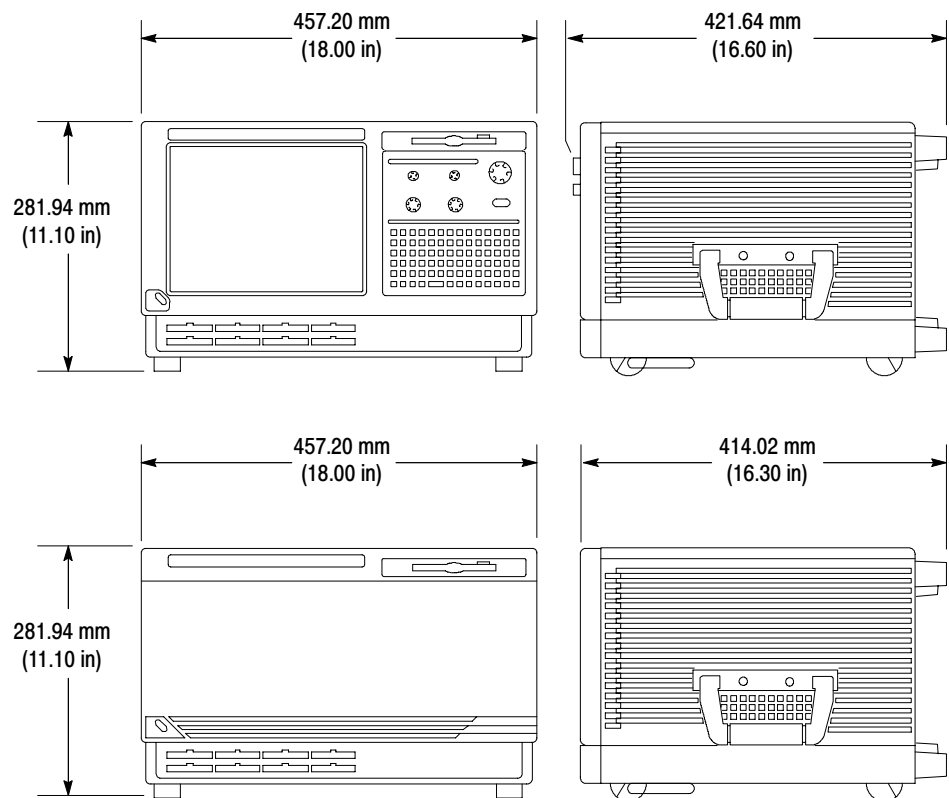

Figure 1: Dimensions of the TLA600 series logic analyzer

TLA5000 Series Logic Analyzer Specifications

Tables 18 through 32 list the specifications for the TLA5000 series logic analyzer.

Table 18: TLA5000 input parameters with probes

| Characteristic | Description |
|--|---|
| ✓ Threshold Accuracy | ±100 mV |
| Threshold range and step size | Settable from +4.5 V to -2 V in 5 mV steps |
| Threshold channel selection | 16 threshold groups assigned to channels. P6417, P6418 and P6419 probes have two threshold settings, one for the clock/qualifier channel and one for the data channels. P6434 probes have four threshold settings, one for each of the clock/qualifier channels and two for the data channels (one per 16 data channels). |
| ✓ Channel-to-channel skew | ≤ 1 ns maximum |
| Channel-to-channel skew (Typical) | ≤ 0.9 ns |
| Sample uncertainty | |
| Asynchronous: | Sample period |
| Synchronous: | 125 ps |
| Probe input resistance (Typical) | 20 kΩ |
| Probe input capacitance: P6417, P6434 (Typical) | 2 pF |
| Probe input capacitance: P6418 (Typical) | 1.4 pF data channels 2 pF CLK/Qual channels |
| P6419 input capacitance: P6419 (Typical) | < 0.7 pF |
| Minimum slew rate (Typical) | 0.2 V/ns |
| Maximum operating signal | 6.0 V _{p-p} -3.5 V absolute input voltage minimum 6.5 V absolute input voltage maximum |
| Probe overdrive: P6417, P6418, P6419 P6434 | ±250 mV or ±25% of signal swing minimum required beyond threshold, whichever is greater ±300 mV or ±25% of signal swing minimum required beyond threshold, whichever is greater ±4 V maximum beyond threshold |
| Maximum nondestructive input signal to probe | ±15 V |

Table 18: TLA5000 input parameters with probes (Cont.)

| Characteristic | Description |
|---|---|
| Minimum input pulse width signal (single channel) (Typical) | 1.5 ns (P6434) 1.25 ns (P6417, P6418, P6419) |
| Delay time from probe tip to module input probe connector (Typical) | 7.33 ns ±100ps |

Table 19: TLA5000 timing latencies

| Characteristic | Description |
|---|---------------|
| System Trigger and External Signal Input Latencies ¹ (Typical) | |
| External System Trigger Input to LA Probe Tip | -594 ns |
| External Signal Input to LA Probe Tip via Signal 3, 4 | -594 ns + Clk |
| External Signal Input to LA Probe Tip via Signal 1, 2 ² | -594 ns + Clk |
| System Trigger and External Signal Output Latencies (Typical) | |
| LA Probe Tip to External System Trigger Out ³ | 760 ns + SMPL |
| LA Probe Tip to External Signal Out via Signal 3, 4 ³ | |
| OR function | 760 ns + SMPL |
| AND function | 760 ns + SMPL |
| LA Probe Tip to External Signal Out via Signal 1, 2 ^{2, 3} | |
| normal function | 760 ns + SMPL |
| inverted logic on backplane | 760 ns + SMPL |

¹ All system trigger and external signal input latencies are measured from a falling-edge transition (active true low) with signals measured in the wired-OR configuration.

² Signals 1 and 2 (ECLTRG0, 1) are limited to a “broadcast” mode of operation, where only one source is allowed to drive the signal node at any one time. That single source may be utilized to drive any combination of destinations.

³ SMPL represents the time from the event at the probe tip inputs to the next valid data sample. In the Normal Internal clock mode, this represents the delta time to the next sample clock. In the MagniVu Internal clock mode, this represents 500 ps or less. In the External clock mode, this represents the time to the next master clock generated by the setup of the clocking state machine, the system-under-test supplied clocks, and the qualification data.

Table 20: TLA5000 external signal interface

| Characteristic | Description |
|--|---|
| System Trigger Input | TTL compatible input via rear panel mounted BNC connectors |
| Input Levels V_{IH} V_{IL} | TTL compatible input $\geq 2.0\text{ V}$ $\leq 0.8\text{ V}$ |
| Input Mode | Falling edge sensitive, latched (active low) |
| Minimum Pulse Width | 12 ns |
| Active Period | Accepts system triggers during valid acquisition periods via real-time gating, resets system trigger input latch between valid acquisition periods. |
| Maximum Input Voltage | 0 to +5 V peak |
| External Signal Input | TTL compatible input via rear panel mounted BNC connectors |
| Input Destination | Signal 1, 2, 3, 4 |
| Input Levels V_{IH} V_{IL} | TTL compatible input $\geq 2.0\text{ V}$ $\leq 0.8\text{ V}$ |
| Input Mode | Active (true) low, level sensitive |
| Input Bandwidth ¹ Signal 1, 2, 3, 4 | 50 MHz square wave minimum |
| Active Period | Accepts signals during valid acquisition periods via real-time gating. |
| Maximum Input Voltage | 0 to +5 V peak |
| System Trigger Output | TTL compatible output via rear panel mounted BNC connectors |
| Source Mode | Active (true) low, falling edge latched |
| Active Period | Outputs system trigger state during valid acquisition period, resets system trigger output to false state between valid acquisitions. |
| Output Levels V_{OH} V_{OL} | 50 Ω back terminated TTL-compatible output $\geq 4\text{ V}$ into open circuit $\geq 2\text{ V}$ into 50 Ω to ground $\leq 0.7\text{ V}$ sinking 10 mA |
| Output Protection | Short-circuit protected (to ground) |
| External Signal Output | TTL compatible outputs via rear panel mounted BNC connectors |
| Source Selection | Signal 1, 2, 3, 4, or 10 MHz clock |
| Output Modes Level Sensitive | User definable Active (true) low or active (true) high |
| Output Levels V_{OH} V_{OL} | 50 Ohm back terminated TTL output $\geq 4\text{ V}$ into open circuit $\geq 2\text{ V}$ into 50 Ω to ground $\leq 0.7\text{ V}$ sinking 10 mA |
| Output Bandwidth ¹ Signal 1, 2, 3, 4 | 50 MHz square wave minimum |

Table 20: TLA5000 external signal interface (Cont.)

| Characteristic | Description |
|-------------------|--|
| Active Period | Outputs signals during valid acquisition periods, resets signals to false state between valid acquisitions. Outputs 10 MHz clock continuously |
| Output Protection | Short-circuit protected (to ground) |

¹ **The Output Bandwidth specification only applies to signals from the modules; it does not apply to signals applied to the External Signal Input and sent back to the External Signal Output.**

Table 21: TLA5000 channel width and depth

| Characteristic | Description | |
|--------------------------|-------------|--|
| Number of channels | Product | Channels |
| | TLA5201 | 32 data and 2 clock |
| | TLA5202 | 64 data and 4 clock |
| | TLA5203 | 96 data, 4 clock, and 2 qualifier |
| | TLA5204 | 128 data, 4 clock, and 4 qualifier |
| Acquisition memory depth | Product | Memory depth |
| | TLA520X | 512 K or optionally either 2 or 8 M samples ¹ |

¹ **PowerFlex options**

Table 22: TLA5000 clocking

| Characteristic | Description | |
|---|--|--------------------|
| Asynchronous clocking | | |
| ✓ Internal sampling period ¹ | 500 ps to 50 ns in a 1-2-5 sequence. Storage control can be used to only store data when it has changed (transitional storage) 2 ns minimum for all channels 1 ns minimum for half channels (using 2:1 demultiplex mode) 0.5 ns minimum for quarter channels (using 4:1 demultiplex mode) | |
| ✓ Minimum recognizable word ² (across all channels) | Channel-to-channel skew + sample uncertainty Example: for a P6419, or P6434 Probe and a 2 ns sample period = 1 ns + 2 ns = 3 ns | |
| Synchronous clocking | | |
| Number of clock channels ³ | Product | Clock channels |
| | TLA5201 | 2 |
| | TLA5202 | 4 |
| | TLA5203 | 4 |
| | TLA5204 | 4 |
| Number of qualifier channels ⁴ | Product | Qualifier channels |
| | TLA5201 | 0 |
| | TLA5202 | 0 |
| | TLA5203 | 2 |
| | TLA5204 | 4 |
| ✓ Setup and hold window size (data and qualifiers) | Maximum window size = Maximum channel-to-channel skew + (2 x sample uncertainty) + Margin = 1.875 ns | |
| Setup and hold window size (data and qualifiers) (Typical) | Channel-to-channel skew (<i>typical</i>) + (2 x sample uncertainty) = 1.5 ns | |
| Setup and hold window range | For each channel, the setup and hold window can be moved from +8.0 ns (Ts) to -8.0 ns (Ts) in 0.125 ns steps (setup time). Hold time follows the setup time by the setup and hold window size. | |
| ✓ Maximum synchronous clock rate | 235 MHz in full speed mode (4.25 ns minimum between active clock edges) | |

Table 22: TLA5000 clocking (Cont.)

| Characteristic | Description |
|--|---|
| 2X Demux clocking | |
| TLA5203 TLA5204 | Any individual channel may be demultiplexed with its partner channel. Channels demultiplex as follows: A3(7:0) to/from D3(7:0) A2(7:0) to/from D2(7:0) A1(7:0) to/from D1(7:0) A0(7:0) to/from D0(7:0) C3(7:0) to/from C1(7:0) C2(7:0) to/from C0(7:0) E3(7:0) to/from E1(7:0) TLA5204 only E2(7:0) to/from E0(7:0) TLA5204 only CK3 to/from Q2 TLA5204 only CK2 to/from Q3) TLA5204 only CK1 to/from Q0 CK0 to/from Q1 |
| TLA5201 TLA5202 | Any individual channel may be demultiplexed with its partner channel. Channels demultiplex as follows: A3(7:0) to/from C3(7:0) A2(7:0) to/from C2(7:0) A1(7:0) to/from D1(7:0) TLA5202 only A0(7:0) to/from D0(7:0) TLA5202 only |
| Time between Demultiplex clock edges (Typical) | Same limitations as normal synchronous acquisition |
| 4X Demux clocking | |
| TLA5203 TLA5204 | Unlike 2X demultiplexing, the channels within a group of four cannot arbitrarily drive the others. E3(7:0) to E2(7:0), E1(7:0), E0(7:0) TLA5204 only A3(7:0) to A2(7:0), D3(7:0), D2(7:0) A1(7:0) to A0(7:0), D1(7:0), D0(7:0) C3(7:0) to C2(7:0), C1(7:0), C0(7:0) CK3 to CK2, Q3, Q2 TLA5204 only CK1 to CK0, Q1, Q0 |
| TLA5201 TLA5202 | Unlike 2X demultiplexing, the channels within a group of four cannot arbitrarily drive the others. A1(7:0) to A0(7:0), D1(7:0), D0(7:0) TL:A5202 only C3(7:0) to C2(7:0), A3(7:0), A2(7:0) |
| Time between Demultiplex clock edges (Typical) | Same limitations as normal synchronous acquisition |

Table 22: TLA5000 clocking (Cont.)

| Characteristic | Description |
|-------------------------------|---|
| Clocking state machine | |
| Pipeline delays | Each channel can be programmed with a pipeline delay of 0 through 7 active clock edges. |
| 1 | It is possible to use storage control and only store data when it has changed (transitional storage). |
| 2 | Applies to asynchronous clocking only. Setup and hold window specification applies to synchronous clocking only. |
| 3 | Any or all of the clock channels may be enabled. For an enabled clock channel, either the rising, falling, or both edges can be selected as the active clock edges. The clock channels are stored. |
| 4 | All qualifier channels are stored. For custom clocking there are an additional 4 qualifier channels on C2 3:0 regardless of channel width. |

Table 23: TLA5000 trigger system

| Characteristic | Description | | | | | | | | | | |
|--|--|---------------------|---------------------|---------------------|--------------------|---------------------|---------------------|--------------------|---------------------|--------------------|---------------------|
| Triggering Resources | | | | | | | | | | | |
| Word/Range recognizers | 16 word recognizers. The word recognizers can be combined to form full width, double bounded, range recognizers. The following selections are available: <table border="0"> <tr> <td>16 word recognizers</td> <td>0 range recognizers</td> </tr> <tr> <td>13 word recognizers</td> <td>1 range recognizer</td> </tr> <tr> <td>10 word recognizers</td> <td>2 range recognizers</td> </tr> <tr> <td>7 word recognizers</td> <td>3 range recognizers</td> </tr> <tr> <td>4 word recognizers</td> <td>4 range recognizers</td> </tr> </table> | 16 word recognizers | 0 range recognizers | 13 word recognizers | 1 range recognizer | 10 word recognizers | 2 range recognizers | 7 word recognizers | 3 range recognizers | 4 word recognizers | 4 range recognizers |
| 16 word recognizers | 0 range recognizers | | | | | | | | | | |
| 13 word recognizers | 1 range recognizer | | | | | | | | | | |
| 10 word recognizers | 2 range recognizers | | | | | | | | | | |
| 7 word recognizers | 3 range recognizers | | | | | | | | | | |
| 4 word recognizers | 4 range recognizers | | | | | | | | | | |
| Range recognizer channel order | From most-significant probe group to least-significant probe group: C3 C2 C1 C0 E3 E2 E1 E0 A3 A2 D3 D2 A1 A0 D1 D0 Q3 Q2 Q1 Q0 CK3 CK2 CK1 CK0 Missing channels for modules with fewer than 136 channels are omitted. | | | | | | | | | | |
| Glitch detector ^{1,2} | Channel groups can be enabled to detect glitches. Glitches are subject to pulse width variations of up to ± 125 ps | | | | | | | | | | |
| Minimum detectable glitch pulse width (Typical) | 1.25 ns (single channel with P6434 probe) 1.0 ns (P6417, P6418, P6419 probe) | | | | | | | | | | |
| Setup and hold violation detector ^{1,3} | Any channel can be enabled to detect a setup or hold violation. The range is from 8.0 ns before the clock edge to 8.0 ns after the clock edge in 0.125 ns steps. The channel setup and hold violation size can be individually programmed. The range can be shifted towards the positive region by 0 ns, 4 ns, or 8 ns. With a 0 ns shift, the range is +8 ns to -8 ns; with a 4 ns shift, the range is +12 ns to -4 ns; with an 8 ns shift, the range is +16 ns to 0 ns. The sample point selection region is the same as the setup and hold window. Any setup value is subject to variation of up to the channel skew specification. Any hold value is subject to variation of up to the channel skew specification. | | | | | | | | | | |

Table 23: TLA5000 trigger system (Cont.)

| Characteristic | Description |
|------------------------------------|--|
| Transition detector ¹ | 16 transition detectors. Any channel group can be enabled or disabled to detect a rising transition, a falling transition, or both rising and falling transitions between the current valid data sample and the previous valid data sample. |
| Counter/Timers | 2 counter/timers, 51 bits wide, can be clocked up to 500 MHz. Maximum count is $2^{51}-1$. Maximum time is 4.5×10^6 seconds or 52 days. Counters and timers can be set, reset, or tested and have zero reset latency. |
| External Signal In ¹ | A backplane input signal. |
| External Trigger In | A backplane input signal that causes both the main acquisition and the MagniVu acquisition to trigger if they are not already triggered. |
| Active trigger resources | 16 maximum (excluding counter/timers) Word recognizers are traded off one-by-one as External Signal In, glitch detection, setup and hold detection, or transition detection resources are added. |
| Trigger States | 16 |
| ✓ Trigger State sequence rate | Same rate as valid data samples received, 500 MHz maximum. |
| Trigger Machine Actions | |
| Main acquisition trigger | Triggers the main acquisition memory. |
| Main trigger position | Trigger position is programmable to any data sample (2 ns boundaries). |
| MagniVu™ acquisition trigger | Triggering of MagniV memory is controlled by the main acquisition trigger machine. |
| MagniVu™ trigger position | The MagniV trigger position is programmable within 2 ns boundaries and separate from the main acquisition memory trigger position. |
| Increment & decrement counter | Either of the two counter/timers used as counters can be increased or decreased. |
| Reloadable word recognizer | Loads the current acquired data sample into the reference value of the word recognizer via a trigger machine action. All data channels are loaded into their respective word recognizer reference register on a one-to-one manner. |
| Reloadable word recognizer latency | 378 ns |
| Start/Stop timer | Either of the two counter/timers used as timers can be started or stopped. |
| Reset counter/timer | Either of the two counter/timers can be reset. When a counter/timer is used as a timer and is reset, the timer continues from the started or stopped state that it was in prior to the reset. |
| Signal out | A signal sent to the backplane to be used by other instruments. |
| Trigger out | A trigger out signal sent to the backplane to trigger other instruments. |

Table 23: TLA5000 trigger system (Cont.)

| Characteristic | Description |
|----------------------------------|--|
| Storage Control | |
| Global storage | <p>Storage is allowed only when a specific condition is met. This condition can use any of the trigger machine resources except for the counter/timers. Storage commands defined in the current trigger state will override the global storage control.</p> <p>Global storage can be used to start the acquisition with storage initially turned on (default) or turned off.</p> |
| By event | Storage can be turned on or off; only the current sample can be stored. The event storage control overrides any global storage commands. |
| Block storage | <p>When enabled, 31 samples are stored before and after the valid sample.</p> <p>Not allowed when glitch storage or setup and hold violation is enabled.</p> |
| Glitch violation storage | The acquisition memory can be enabled to store glitch violation information with each data sample when asynchronous clocking is used. The probe data storage size is reduced by one half (the other half holds the violation information). The fastest asynchronous clocking rate is reduced to 4 ns. |
| Setup and hold violation storage | The acquisition memory can be enabled to store setup and hold violation information with each data sample when synchronous clocking is used. The probe data storage size is reduced by one half (the other half holds the violation information). The maximum clock rate in this mode is 235 MHz. |

- ¹ **Each use of External Signal In, glitch detector, setup and hold violation detector, or transition detector requires a trade-off of one word recognizer resource.**
- ² **Any glitch is subject to pulse width variation of up to the channel-to-channel skew specification + 0.25 ns.**
- ³ **Any setup value is subject to variation of up to the channel skew specification. Any hold value is subject to variation of the channel skew specifications.**

Table 24: TLA5000 MagniVu™ feature

| Characteristic | Description |
|-------------------------|--|
| MagniVu memory depth | 16,000 samples per channel |
| MagniVu sampling period | Data is asynchronously sampled and stored every 125 ps in a separate high resolution memory. The storage speed may be changed (by software) to 250 ps, 500 ps, or 1000 ps so that MagniVu memory covers more time at a lower resolution. |

Table 25: TLA5000 Data handling

| Characteristic | Description |
|---|---|
| Nonvolatile memory retention time (Typical) | Battery is integral to the NVRAM. Battery life is > 10 years. |

Table 26: TLA5000 internal controller

| Characteristic | Description |
|---|--|
| Operating System | Microsoft Windows |
| Microprocessor | Intel Celeron, 2 GHz |
| Main Memory | PC2100 DDR SDRAM |
| Style | 184 pin DIMM, 2 Sockets |
| Speed | 100 MHz |
| Installed configuration | 512 MB loaded in one socket |
| Real-Time Clock and CMOS Setups, Plug & Play NVRAM Retention Time | Battery life is typically > 3 years when the logic analyzer is not connected to line voltage. When connected to line voltage the life of the battery is extended. Lithium battery, CR2032 |
| Hard Disk Drive | Standard PC compatible IDE (Integrated Device Electronics) hard disk drive residing on an EIDE interface. |
| Size | Formatted capacity 80 GByte Continually subject to change due to the fast-moving PC component environment. These storage capacities valid at product introduction. |
| CD-RW Drive | Standard PC compatible IDE (Integrated Device Electronics) CD-RW drive residing on an EIDE interface. Continually subject to change due to the fast-moving PC component environment. |
| Floppy Disk Drive | Standard 3.5 inch 1.44-MB PC compatible high-density, double-sided floppy disk drive. |

Table 27: TLA5000 display system

| Characteristic | Description |
|--|---|
| Classification | Standard PC graphics accelerator technology (bitBLT-based); capable of supporting both internal color LCD display and external color SVGA/XGA monitor. |
| Display Memory Size | SDRAM-onboard the ATI Mobility I video controller clocked up to 100 MHz. 8 MB |
| Display Selection | Both front panel and external displays can be used simultaneously, each with independent resolutions. Supports Windows dual-monitor capability. |
| External Display Drive | Two XGA-compatible analog output ports |
| Primary Display Size (RAGE M1 chip) | Selected via Windows Resolution (Pixels) Colors 1024 x 768 256, 64 K, 16.8 M |
| Secondary Display Size (845GV chip) | Selected via Windows Resolution (Pixels) Colors 640 x 480 256, 64 K, 16.8 M 800 x 600 256, 64 K, 16.8 M 1024 x 768 256, 64 K, 16.8 M 1280 x 1024 256, 64 K, 16.8 M 1600 x 1200 256, 64 K, 16.8 M 1920 x 1440 256, 64K |
| Internal Display | |
| Classification | Thin Film Transistor (TFT) 10.4 inch active-matrix color LCD display; CCFL backlight; intensity controllable via software. |
| Resolution | 1024 x 768 pixels |
| Color Scale | 256K |

Table 28: TLA5000 front-panel interface

| Characteristic | Description |
|------------------------|--|
| QWERTY Keypad | ASCII keypad to support naming of files, traces, and keyboard equivalents of pointing device inputs for menus. |
| Special Function Knobs | Various functions |

Table 29: TLA5000 rear-panel interface

| Characteristic | Description |
|-------------------------------|---|
| Parallel Interface Port (LPT) | 25-pin sub-D Parallel Port Connector, Extended Parallel Port (EPP), or Enhanced Capabilities Port (ECP) |
| Serial Interface Port (COM 1) | 9-pin male sub-D connector to support RS-232 serial port |
| Two USB Ports | Two USB 2.0 (Universal Serial Bus) compliant ports |
| SVGA Output Ports (SVGA OUT) | 15-pin sub-D SVGA connectors (two each, one Primary, one Secondary) |
| Mouse Port | PS/2 compatible mouse port utilizing a mini DIN connector |
| Keyboard Port | PS/2 compatible keyboard port utilizing a mini DIN connector |

Table 30: TLA5000 AC power source

| Characteristic | Description |
|---------------------------------|--|
| Source Voltage and Frequency | 100-240 VAC \pm 10%, 47-63 Hz, continuous range CAT II |
| Maximum Power Consumption | 225 Watts line power maximum |
| Steady-State Input Current | 4 A _{RMS} maximum |
| Inrush Surge Current | 65 A maximum |
| Power Factor Correction | Yes |
| On/Standby Switch and Indicator | Front Panel On/Standby switch, with indicator. The power cord provides main power disconnect. |

Table 31: TLA5000 cooling

| Characteristic | Description |
|-------------------|---|
| Cooling System | Forced air circulation (negative pressurization) utilizing two fans operating in parallel |
| Cooling Clearance | 51 mm (2 in), sides and rear; unit should be operated on a flat, unobstructed surface |

Table 32: TLA5000 mechanical characteristics

| Characteristic | Description |
|--------------------|--|
| Overall Dimensions | See Figure 1 for overall chassis dimensions |
| Weight | Includes empty accessory pouch and front cover |
| TLA5201 | 11.8 Kg (25 lb 15 oz) |
| TLA5202 | 11.85 Kg (26 lb 2 oz) |
| TLA5203 | 11.9 Kg (26 lb 4 oz) |
| TLA5204 | 12 Kg (26 lb 7 oz) |

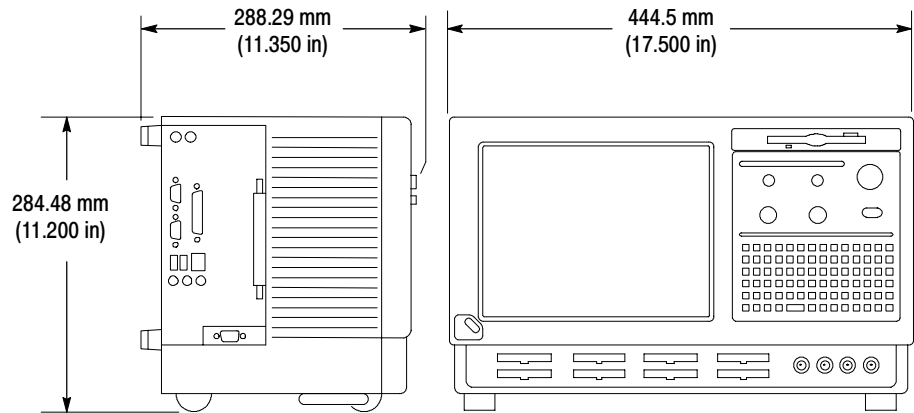

Figure 2: Dimensions of the TLA5000 series logic analyzer

TLA700 System Specifications

Tables 33 through 35 list the specifications common to the TLA715, TLA714, TLA720, and TLA721 logic analyzers. Detailed specifications for the individual logic analyzers begin on page 36.

Table 33: TLA700 Backplane interface

| Characteristic | Description |
|--|--|
| Slots | |
| Portable mainframe | 4 |
| Benchtop mainframe | 10 (three slots taken up by the controller module) |
| Expansion mainframe | 13 |
| ✓ CLK10 Frequency | 10 MHz ±100 PPM |
| Relative Time Correlation Error ^{1,2} (Typical) | |
| TLA7Lx/Mx/Nx/Px/Qx to TLA7Lx/Mx/Nx/Px/Qx “MagniVu” data | 2 ns |
| TLA7Axx to TLA7Axx “MagniVu” data | 2 ns |
| TLA7Axx to TLA7Lx/Mx/Nx/Px/Qx “MagniVu” data | -3 ns |
| TLA7Lx/Mx/Nx/Px/Qx to TLA7Lx/Mx/Nx/Px/Qx “normal” data using an internal clock | 1 TLA7Lx/Mx/Nx/Px/Qx sample - 0.5 ns |
| TLA7Axx to TLA7Axx “normal” data using an internal clock | 1 TLA7Axx sample - 0.5 ns |
| TLA7Axx to TLA7Lx/Mx/Nx/Px/Qx “normal” data using an internal clock | 1 TLA7Lx/Mx/Nx/Px/Qx sample - 0.5 ns |
| TLA7Lx/Mx/Nx/Px/Qx to TLA7Lx/Mx/Nx/Px/Qx “normal” data using an external clock | 2 ns |
| TLA7Axx to TLA7Axx “normal” data using an external clock | 2 ns |
| TLA7Axx to TLA7Lx/Mx/Nx/Px/Qx “normal” data using an external clock | 4 ns |
| TLA7Lx/Mx/Nx/Px/Qx “MagniVu” to DSO data | 3 ns |
| TLA7Axx “MagniVu” to DSO data | 2 ns |
| TLA7Lx/Mx/Nx/Px/Qx to DSO “normal” data using an internal clock ³ | 1 TLA7Lx/Mx/Nx/Px/Qx sample + 2 ns |
| TLA7Axx to DSO “normal” data using an internal clock ³ | 1 TLA7Axx sample + 2 ns |
| TLA7Lx/Mx/Nx/Px/Qx to DSO “normal” data using an external clock ³ | 3 ns |
| TLA7Axx to DSO “normal” data using an external clock ³ | 2 ns |
| DSO to DSO ³ | 3 ns |

¹ Includes typical jitter, slot-to-slot skew, and probe-to-probe variations to provide a “typical” number for the measurement. Assumes standard accessory probes are utilized.

² For time intervals longer than 1 μs between modules, add 0.01% of the difference between the absolute time measurements to the relative time correlation error to account for the inaccuracy of the CLK10 source.

³ The DSO module time correlation is measured at the maximum sample rate on one channel only.

Table 34: TLA700 Backplane latencies

| Characteristic | Portable mainframe and benchtop mainframe | Expansion mainframe |
|---|---|---------------------|
| System trigger and external signal input latencies ² (Typical) | | |
| External system trigger input to TLA7Lx/Mx/Nx/Px/Qx probe tip ⁴ | -266 ns | -230 ns |
| External system trigger input to TLA7Axx probe tip ⁴ | -653 ns | -617 ns |
| External signal input to TLA7Lx/Mx/Nx/Px/Qx probe tip via Signal 3, 4 ⁵ | -212 ns + Clk | -176 ns + Clk |
| External signal input to TLA7Axx probe tip via Signal 3, 4 ⁵ | -212 ns + Clk | -176 ns + Clk |
| External signal input to TLA7Lx/Mx/Nx/Px/Qx probe tip via Signal 1, 2 ^{5, 6} | -634 ns + Clk | -596 ns + Clk |
| External signal input to TLA7Axx probe tip via Signal 1, 2 ^{5, 6} | -636 ns + Clk | -615 ns + Clk |
| External system trigger input to DSO probe tip ⁴ | -25 ns | 11 ns |
| System trigger and external signal output latencies ¹ (Typical) | | |
| TLA7Lx/Mx/Nx/Px/Qx probe tip to external system trigger out | 376 ns + SMPL | 412 ns + SMPL |
| TLA7Axx probe tip to external system trigger out | 794 ns + SMPL | 830 ns + SMPL |
| TLA7Lx/Mx/Nx/Px/Qx probe tip to external signal out via Signal 3, 4 ³ | | |
| OR function | 366 ns + SMPL | 402 ns + SMPL |
| AND function | 379 ns + SMPL | 415 ns + SMPL |
| TLA7Axx probe tip to external signal out via Signal 3, 4 ³ | | |
| OR function | 792 ns + SMPL | 828 ns + SMPL |
| AND function | 800 ns + SMPL | 836 ns + SMPL |
| TLA7Lx/Mx/Nx/Px/Qx probe tip to external signal out via Signal 1, 2 ^{3, 6} | | |
| normal function | 364 ns + SMPL | 385 ns + SMPL |
| inverted logic on backplane | 364 ns + SMPL | 385 ns + SMPL |
| TLA7Axx probe tip to external signal out via Signal 1, 2 ^{3, 6} | | |
| normal function | 796 ns + SMPL | 817 ns + SMPL |
| inverted logic on backplane | 796 ns + SMPL | 817 ns + SMPL |

Table 34: TLA700 Backplane latencies (Cont.)

| Characteristic | Portable mainframe and benchtop mainframe | Expansion mainframe |
|--|---|---------------------|
| DSO probe tip to external system trigger out | 68 ns | 104 ns |
| DSO Probe tip to external signal out via Signal 3, 4 ³ | | |
| OR function | 65 ns | 101 ns |
| AND function | 75 ns | 111 ns |
| DSO probe tip to external signal out via Signal 1, 2 ^{3,6} | | |
| normal function | 68 ns | 89 ns |
| inverted logic on backplane | 71 ns | 92 ns |
| Inter-module latencies (Typical) | | |
| TLA7Lx/Mx/Nx/Px/Qx to DSO inter-module system trigger ^{1,4} | 358 ns + SMPL | 394 ns + SMPL |
| TLA7Axx to DSO inter-module system trigger ^{1,4} | 772 ns + SMPL | 808 ns + SMPL |
| TLA7Lx/Mx/Nx/Px/Qx to TLA7Lx/Mx/Nx/Px/Qx inter-module system trigger ^{1,4} | 66 ns + SMPL | 102 ns + SMPL |
| TLA7Axx to TLA7Lx/Mx/Nx/Px/Qx inter-module system trigger ^{1,4} | 479 ns + SMPL | 515 ns + SMPL |
| TLA7Axx to TLA7Axx inter-module system trigger ^{1,4} | 116 ns + SMPL | 152 ns + SMPL |
| TLA7Lx/Mx/Nx/Px/Qx to DSO inter-module ARM ¹ | 360 ns + SMPL | 396 ns + SMPL |
| TLA7Axx to DSO inter-module ARM ¹ | 779 ns + SMPL | 815 ns + SMPL |
| TLA7Lx/Mx/Nx/Px/Qx to TLA7Lx/Mx/Nx/Px/Qx inter-module ARM ^{1,5} | 108 ns + SMPL + Clk | 144 ns + SMPL + Clk |
| TLA7Axx to TLA7Lx/Mx/Nx/Px/Qx inter-module ARM ^{1,5} | 479 ns + SMPL + Clk | 533 ns + SMPL + Clk |
| TLA7Axx to TLA7Axx inter-module ARM ^{1,5} | 111 ns + SMPL + Clk | 147 ns + SMPL + Clk |
| TLA7Lx/Mx/Nx/Px/Qx to TLA7Lx/Mx/Nx/Px/Qx inter-module via Signal 1, 2 ^{1,5,6} | 116 ns + SMPL + Clk | 137 ns + SMPL + Clk |
| TLA7Axx to TLA7Axx inter-module via Signal 1, 2 ^{1,5,6} | 113 ns + SMPL + Clk | 134 ns + SMPL + Clk |
| TLA7Axx to TLA7Lx/Mx/Nx/Px/Qx inter-module via Signal 1, 2 ^{1,5,6} | 534 ns + SMPL + Clk | 555 ns + SMPL + Clk |
| TLA7Lx/Mx/Nx/Px/Q to TLA7Lx/Mx/Nx/Px/Qx inter-module via Signal 3, 4 ^{1,5} | 116 ns + SMPL + Clk | 152 ns + SMPL + Clk |
| TLA7Axx to TLA7Axx inter-module via Signal 3, 4 ^{1,5} | 124 ns + SMPL + Clk | 160 ns + SMPL + Clk |
| TLA7Axx to TLA7Lx/Mx/Nx/Px/Qx inter-module via Signal 3, 4 ^{1,5} | 545 ns + SMPL + Clk | 581 ns + SMPL + Clk |
| TLA7Lx/Mx/Nx/Px/Qx to TLA7Axx inter-module System Trigger ^{1,4} | -287 ns + SMPL | -251 ns + SMPL |

Table 34: TLA700 Backplane latencies (Cont.)

| Characteristic | Portable mainframe and benchtop mainframe | Expansion mainframe |
|---|---|----------------------|
| DSO to TLA7Lx/Mx/Nx/Px/Qx inter-module System Trigger ⁴ | -240 ns | -204 ns |
| DSO to TLA7Axx inter-module System Trigger ⁴ | -598 ns | -562 ns |
| DSO to DSO inter-module System Trigger ⁴ | 50 ns | 86 ns |
| TLA7Lx/Mx/Nx/Px/Qx to TLA7Axx inter-module ARM ^{1,5} | -300 ns + SMPL + Clk | -264 ns + SMPL + Clk |
| DSO to TLA7Lx/Mx/Nx/Px/Qx inter-module ARM ⁵ | -192 ns + Clk | -156 ns + Clk |
| DSO to TLA7Axx inter-module ARM ⁵ | -600 ns + Clk | -564 ns + Clk |
| DSO to DSO inter-module ARM | 59 ns | 95 ns |
| DSO to TLA7Lx/Mx/Nx/Px/Qx inter-module via Signal 1, 2 ^{5,6} | -179 ns + Clk | -158 ns + Clk |
| TLA7Lx/Mx/Nx/Px/Qx to TLA7Axx inter-module via Signal 1, 2 ^{1,5,6} | -294 ns + SMPL + Clk | -273 ns + SMPL + Clk |
| DSO to TLA7Axx inter-module via Signal 1, 2 ^{5,6} | -598ns + Clk | -577 ns + Clk |
| TLA7Lx/Mx/Nx/Px/Qx to TLA7Axx inter-module via Signal 3, 4 ^{1,5} | -294 ns + SMPL + Clk | -258 ns + SMPL + Clk |
| DSO to TLA7Lx/Mx/Nx/Px/Qx inter-module via Signal 3, 4 ⁵ | -184 ns + Clk | -148 ns + Clk |
| DSO to TLA7Axx inter-module via Signal 3, 4 ⁵ | -598 ns + Clk | -562 ns + Clk |

- ¹ **SMPL** represents the time from the event at the probe tip inputs to the next valid data sample of the LA module. In the Normal Internal clock mode, this represents the delta time to the next sample clock. In the MagniVu Internal clock mode, this represents 500 ps or less. In the External clock mode, this represents the time to the next master clock generated by the setup of the clocking state machine, the system-under-test supplied clocks, and the qualification data.
- ² All system trigger and external signal input latencies are measured from a falling-edge transition (active true low) with signals measured in the wired-OR configuration.
- ³ All signal output latencies are validated to the rising edge of an active (true) high output.
- ⁴ In the Waveform window, triggers are always marked immediately except when delayed to the first sample. In the Listing window, triggers are always marked on the next sample period following their occurrence.
- ⁵ “Clk” represents the time to the next master clock at the destination logic analyzer. In the asynchronous (or internal) clock mode, this represents the delta time to the next sample clock beyond the minimum asynchronous rate of 4 ns. In the synchronous (or external) clock mode, this represents the time to the next master clock generated by the setup of the clocking state machine and the supplied system under test clocks and qualification data.
- ⁶ Signals 1 and 2 are limited to a “broadcast” mode of operation, where only one source is allowed to drive the signal node at any one time. That single source may be utilized to drive any combination of destinations.

Table 35: TLA700 External signal interface

| Characteristic | Description |
|--|--|
| System Trigger Input | TTL compatible input via rear panel mounted BNC connectors (portable mainframe) or front panel mounted SMB connectors (benchtop mainframe) |
| Input Levels V_{IH} V_{IL} | TTL compatible input $\geq 2.0\text{ V}$ $\leq 0.8\text{ V}$ |
| Input destination | System trigger |
| Input Mode | Falling edge sensitive, latched (active low) |
| Minimum Pulse Width | 12 ns |
| Active Period | Accepts system triggers during valid acquisition periods via real-time gating, resets system trigger input latch between valid acquisition periods |
| Maximum Input Voltage | 0 to +5 V peak |
| External Signal Input | TTL compatible input via rear panel mounted BNC connectors (portable mainframe) or front panel mounted SMB connectors (benchtop mainframe) |
| Input Destination | Signal 1, 2 Signal 3, 4 |
| Input Levels V_{IH} V_{IL} | TTL compatible input $\geq 2.0\text{ V}$ $\leq 0.8\text{ V}$ |
| Input Mode | Active (true) low, level sensitive |
| Input Bandwidth ¹ Signal 1, 2 Signal 3, 4 | 50 MHz square wave minimum 10 MHz square wave minimum |
| Active Period | Accepts signals during valid acquisition periods via real-time gating |
| Maximum Input Voltage | 0 to +5 V peak |
| System Trigger Output | TTL compatible output via rear panel mounted BNC connectors (portable mainframe) or front panel mounted SMB connectors (benchtop mainframe) |
| Source selection | System trigger |
| Source Mode | Active (true) low, falling edge latched |
| Active Period | Outputs system trigger state during valid acquisition period, resets system trigger output to false state between valid acquisitions |
| Output Levels V_{OH} | 50 Ω back terminated TTL-compatible output $\geq 4\text{ V}$ into open circuit $\geq 2\text{ V}$ into 50 Ω to ground |
| V_{OL} | $\leq 0.7\text{ V}$ sinking 10 ma |
| Output Protection | Short-circuit protected (to ground) |

Table 35: TLA700 External signal interface (Cont.)

| Characteristic | Description |
|---|---|
| External Signal Output | TTL compatible outputs via rear panel mounted BNC connectors (portable mainframe) or front panel mounted SMB connectors (benchtop mainframe) |
| Source Selection | Signal 1, 2 Signal 3, 4 10 MHz clock |
| Output Modes Level Sensitive | User definable Active (true) low or active (true) high |
| Output Levels V_{OH} | 50 Ω back terminated TTL output ≥ 4 V into open circuit ≥ 2 V into 50 Ω to ground |
| V_{OL} | ≤ 0.7 V sinking 10 ma |
| Output Bandwidth ² Signal 1, 2 Signal 3, 4 | 50 MHz square wave minimum 10 MHz square wave minimum |
| Active Period | Outputs signals during valid acquisition periods, resets signals to false state between valid acquisitions Outputs 10 MHz clock continuously |
| Output Protection | Short-circuit protected (to ground) |
| Intermodule signal line bandwidth | Minimum bandwidth up to which the intermodule signals are specified to operate correctly |
| Signal 1, 2 Signal 3, 4 | 50 MHz square wave minimum 10 MHz square wave minimum |

¹ **The Input Bandwidth specification only applies to signals to the modules; it does not apply to signals applied to the External Signal Input and sent back to the External Signal Output.**

² **The Output Bandwidth specification only applies to signals from the modules; it does not apply to signals applied to the External Signal Input and sent back to the External Signal Output.**

TLA715 Dual Monitor Portable Mainframe Characteristics

Tables 36 through 43 describe the specifications for the TLA715 Dual Monitor Portable Mainframe.

Table 36: TLA715 Internal controller

| Characteristic | Description |
|--|--|
| Operating system | Microsoft Windows 2000 |
| Microprocessor | Intel Pentium PC-AT configuration with an Intel 815E chip-set and a 733 MHz Pentium III processor |
| Main memory | SDRAM |
| Style | 144 pin SO DIMM, 2 sockets, gold plated, 1.25-inch (3.175 cm) maximum height |
| Speed | 133 MHz |
| Available configurations | 32, 64, 128, 256 MByte per SO DIMM |
| Installed configurations | 512 MB with both sockets loaded |
| Cache memory | 256 KByte Level 2 (L2) write-back cache |
| Flash BIOS | 256 KByte |
| Real-time clock and CMOS setups NVRAM | Real-time clock/calendar, standard and advanced PC CMOS setups; see BIOS specification |
| RTC, CMOS setup, & PNP NVRAM retention time (typical) | > 10 years battery life, lithium battery |
| Floppy disk drive | Standard 3.5 inch 1.44-MB PC compatible high-density, double-sided floppy disk drive, 500 Kbits/sec transfer rate |
| Bootable replaceable hard disk drive | Standard PC compatible IDE (Integrated Device Electronics) hard disk drive residing on an EIDE interface. |
| Size | 40 GB Continually subject to change due to the fast-moving PC component environment. These storage capacities valid at product introduction. |
| Interface | ATA -5/enhanced IDE (EIDE) |
| Average seek time | Read, 12 ms |
| Average latency | 7/14 ms |
| I/O data transfer rate | 33.3 MBytes/sec maximum (U-DMA mode 2) |
| Cache buffer | 2 MBytes (30 GB) /512 KBytes (10GB) |
| CD-RW drive | Standard PC compatible IDE (Integrated device Electronics) 8x-8x-24x CD-RW drive residing on an IDE interface. Continually subject to change due to the fast-moving PC component environment. |

Table 37: TLA715 display system

| Characteristic | Description | | | | | | | | | | | | | | | | | | | | | |
|---|---|----------------------------|---------------|----------------------|-----------|-------------------|------------|-----------|-------------------|------------|------------|-------------------|------------|-------------|-------------------|------------|-------------|-----------|--------|-------------|-----------|----|
| Classification | Standard PC graphics-accelerator technology capable of supporting both internal color LCD display and two external color VGA, SVGA, or XGA monitors | | | | | | | | | | | | | | | | | | | | | |
| Display memory | 4 MB SDRAM clocked up to 100 MHz, no external video memory | | | | | | | | | | | | | | | | | | | | | |
| Display selection | <p>Hardware sense of external SVGA monitor during BIOS boot sequence; defaults to internal color LCD display (indicated by two beeps); automatically switches to external SVGA monitor, if attached (indicated by one beep).</p> <p>Dual (simultaneous) display of external SVGA monitor and internal color LCD is possible via special CMOS "simulscan" setup, as long as internal and external displays operate at same resolution (limited to 800x600 on current LCD) and display rates (simulscan mode indicated by three beeps).</p> <p>Four beeps during the BIOS boot indicates a monochrome LCD was found (not supported). Five beeps indicates no recognizable LCD or external monitor was found.</p> <p>Dynamic Display Configuration 1 (DDC1) support for external SVGA monitor is provided.</p> | | | | | | | | | | | | | | | | | | | | | |
| External display drive | Two VGA, SVGA, or XGA-compatible analog output ports. Display size is selected via Win2000 display applet. | | | | | | | | | | | | | | | | | | | | | |
| Display Size (Primary video port with Silicon motion chip) | <table border="1"> <thead> <tr> <th><u>Resolution (Pixels)</u></th> <th><u>Colors</u></th> <th><u>Refresh Rates</u></th> </tr> </thead> <tbody> <tr> <td>640 x 480</td> <td>256, 64 K, 16.8 M</td> <td>60, 75, 85</td> </tr> <tr> <td>800 x 600</td> <td>265, 64 K, 16.8 M</td> <td>60, 75, 85</td> </tr> <tr> <td>1024 x 768</td> <td>256, 64 K, 16.8 M</td> <td>60, 75, 85</td> </tr> <tr> <td>1280 x 1024</td> <td>256, 64 K, 16.8 M</td> <td>60</td> </tr> <tr> <td>1600 x 600</td> <td>256, 64 K</td> <td>60</td> </tr> <tr> <td>1600 x 1200</td> <td>256, 64 K</td> <td>60</td> </tr> </tbody> </table> | <u>Resolution (Pixels)</u> | <u>Colors</u> | <u>Refresh Rates</u> | 640 x 480 | 256, 64 K, 16.8 M | 60, 75, 85 | 800 x 600 | 265, 64 K, 16.8 M | 60, 75, 85 | 1024 x 768 | 256, 64 K, 16.8 M | 60, 75, 85 | 1280 x 1024 | 256, 64 K, 16.8 M | 60 | 1600 x 600 | 256, 64 K | 60 | 1600 x 1200 | 256, 64 K | 60 |
| <u>Resolution (Pixels)</u> | <u>Colors</u> | <u>Refresh Rates</u> | | | | | | | | | | | | | | | | | | | | |
| 640 x 480 | 256, 64 K, 16.8 M | 60, 75, 85 | | | | | | | | | | | | | | | | | | | | |
| 800 x 600 | 265, 64 K, 16.8 M | 60, 75, 85 | | | | | | | | | | | | | | | | | | | | |
| 1024 x 768 | 256, 64 K, 16.8 M | 60, 75, 85 | | | | | | | | | | | | | | | | | | | | |
| 1280 x 1024 | 256, 64 K, 16.8 M | 60 | | | | | | | | | | | | | | | | | | | | |
| 1600 x 600 | 256, 64 K | 60 | | | | | | | | | | | | | | | | | | | | |
| 1600 x 1200 | 256, 64 K | 60 | | | | | | | | | | | | | | | | | | | | |
| (Secondary video port with 815E chip set) | <table border="1"> <thead> <tr> <th><u>Resolution (Pixels)</u></th> <th><u>Colors</u></th> <th><u>Refresh Rates</u></th> </tr> </thead> <tbody> <tr> <td>640 x 480</td> <td>256, 64 K, 16.8 M</td> <td>60, 75, 85</td> </tr> <tr> <td>800 x 600</td> <td>256, 64 K, 16.8 M</td> <td>60, 75, 85</td> </tr> <tr> <td>1024 x 768</td> <td>256, 64 K, 16.8 M</td> <td>60, 75, 85</td> </tr> <tr> <td>1280 x 1024</td> <td>256, 64 K, 16.8 M</td> <td>60, 75, 80</td> </tr> <tr> <td>1600 x 1200</td> <td>256</td> <td>60, 75</td> </tr> </tbody> </table> | <u>Resolution (Pixels)</u> | <u>Colors</u> | <u>Refresh Rates</u> | 640 x 480 | 256, 64 K, 16.8 M | 60, 75, 85 | 800 x 600 | 256, 64 K, 16.8 M | 60, 75, 85 | 1024 x 768 | 256, 64 K, 16.8 M | 60, 75, 85 | 1280 x 1024 | 256, 64 K, 16.8 M | 60, 75, 80 | 1600 x 1200 | 256 | 60, 75 | | | |
| <u>Resolution (Pixels)</u> | <u>Colors</u> | <u>Refresh Rates</u> | | | | | | | | | | | | | | | | | | | | |
| 640 x 480 | 256, 64 K, 16.8 M | 60, 75, 85 | | | | | | | | | | | | | | | | | | | | |
| 800 x 600 | 256, 64 K, 16.8 M | 60, 75, 85 | | | | | | | | | | | | | | | | | | | | |
| 1024 x 768 | 256, 64 K, 16.8 M | 60, 75, 85 | | | | | | | | | | | | | | | | | | | | |
| 1280 x 1024 | 256, 64 K, 16.8 M | 60, 75, 80 | | | | | | | | | | | | | | | | | | | | |
| 1600 x 1200 | 256 | 60, 75 | | | | | | | | | | | | | | | | | | | | |
| Internal display | | | | | | | | | | | | | | | | | | | | | | |
| Classification | TFT (Thin Film Transistor) 26 cm active-matrix color LCD display, CCFL backlight, intensity controllable via software | | | | | | | | | | | | | | | | | | | | | |
| Resolution | 800 X 600, 262, 144 colors with 211.2 mm (8.3 in) by 158.4 mm (6.2 in) of viewing area | | | | | | | | | | | | | | | | | | | | | |
| Color scale | 262, 144 colors (6-bit RGB) with a color gamut of 42% at center to NTSC | | | | | | | | | | | | | | | | | | | | | |

Table 38: TLA715 front-panel interface

| Characteristic | Description |
|----------------------------|--|
| QWERTY keypad | 31-key ASCII keypad to support naming of files, traces, and keyboard equivalents of pointing device inputs for menus |
| HEX keypad | 25-key HEX keypad supporting standard DSO and LA entry functions |
| Special function knobs | |
| Multi-function knob | Various increment/decrement functions dependent on screen or window type |
| Vertical position | Scrolling and positioning dependent on display type |
| Vertical scale | Scales waveform displays only |
| Horizontal position | Scrolling and positioning dependent on display type |
| Horizontal scale | Scales waveform displays only |
| Integrated pointing device | Vertically mounted Trackball with two keypad control buttons (SELECT and MENU) |
| USB port | Front panel (lower left-hand side) dual USB connector |
| Mouse Port | PS/2 compatible pointing device port |
| Keyboard Port | PS/2 compatible keyboard port |

Table 39: TLA715 rear-panel interface

| Characteristic | Description |
|-------------------------------|--|
| Parallel interface port | 36-pin high-density connector supports Output only, Enhanced Parallel Port (EPP), or Microsoft high-speed mode (ECP) Complies with IEEE P1284-C/D2 for bi-directional Parallel Peripheral Interface for Personal Computers (draft) style 1284-C |
| Serial interface port | 9-pin male sub-D connector to support RS-232 serial port |
| SVGA output Port 1 and Port 2 | Two 15-pin sub-D SVGA connectors |
| PC CardBus32 port | Standard Type I, II, III PC-compatible, PC card slot Complies with PCMCIA 2.1 and JEIDA 4.1 |

Table 40: TLA715 AC power source

| Characteristic | Description |
|--|---|
| Source voltage and frequency | 90 V _{RMS} to 250 V _{RMS} , 45 Hz to 66 Hz, continuous range CAT II; 100 V _{RMS} to 132 V _{RMS} , 360 Hz to 440 Hz, continuous range CAT II |
| Fuse rating | |
| 90 V to 250 V operation (159-0046-00) | UL198/CSA C22.2 0.25 in × 1.25 in, Fast Blow, 8 A, 250 V |
| 90 V to 250 V operation (159-0381-00) | IEC 127/Sheet 1 5 mm × 20 mm, Fast Blow, 6.3 A, 250 V |
| Maximum power consumption | 600 W |
| Steady-state input current | 6 A _{RMS} maximum at 90 VAC _{RMS} , 60 Hz or 100 VAC _{RMS} , 400 Hz |
| Inrush surge current | 70 A maximum |
| Power factor correction | Yes |
| On/Sleep indicator | Green/yellow front panel LED located next to On/Standby switch provides visual feedback when the On/Off switch is actuated. When the LED is green, the instrument is powered and the processor is not sleeping. When the LED is yellow, the instrument is powered, but the processor is sleeping. |
| On/Standby switch and indicator | Front panel On/Standby switch. Users can push the switch to power down the instrument without going through the Windows shutdown process; the instrument normally powers down. The power cord provides main power disconnect. |

Table 41: TLA715 secondary power

| Characteristic | Description | | | |
|---|-------------|----------|----------|----------|
| ✓ DC Voltage Regulation | Voltage | Minimum | Nominal | Maximum |
| (Combined System, voltage available at each slot) | +24 V | 23.28 V | 24.24 V | 25.20 V |
| | +12 V | 11.64 V | 12.12 V | 12.60 V |
| | +5 V | 4.875 V | 5.063 V | 5.250 V |
| | -2 V | -2.10 V | -2.00 V | -1.90 V |
| | -5.2 V | -5.460 V | -5.252 V | -5.044 V |
| | -12 V | -12.60 V | -12.12 V | -11.64 V |
| | -24 V | -25.20 V | -24.24 V | -23.28 V |

Table 42: TLA715 cooling

| Characteristic | Description |
|-------------------------|--|
| Cooling system | Forced air circulation system with no removable filters using six fans operating in parallel |
| Pressurization | Negative pressurization system in all chambers including modules |
| Slot activation | Installing a module activates the cooling for the corresponding occupied slots by opening the airflow shutter mechanism. Optimizes cooling efficiency by only applying airflow to installed modules. |
| Air intake | Front sides and bottom |
| Air exhaust | Back rear |
| Cooling clearance | 2 inches (51 mm) front, sides, top, and rear. Prevent blockage of airflow to bottom of instrument by placing on a solid, noncompressable surface; can be operated on rear feet. |
| Fan speed and operation | All fans operational at half their rated potential and speed (12 VDC) |

Table 43: TLA715 mechanical

| Characteristic | Description |
|--------------------------------|--|
| Overall dimensions | (See Figure 4 for overall chassis dimensions) Dimensions are without front feet extended, front cover attached, pouch attached, nor power cord attached. |
| Height (with feet) | 9.25 in (23.5 cm) |
| Width | 17 in (43.18 cm) |
| Depth | 17.5 in (44.45 cm) |
| Weight | 30 lbs 12 oz (13.9 kg) with no modules installed, two dual-wide slot covers, and empty pouch |
| Shipping configuration | 60 lbs 13 oz (27.58 kg) minimum configuration (no modules), with all standard accessories 86 lbs 9 oz (39.26 kg) full configuration, with two TLA 7P4 modules and standard accessories (including probes and clips) |
| Acoustic noise level (typical) | 42.7 dBA weighted (operator) 37.0 dBA weighted (bystander) |
| Construction materials | Chassis parts are constructed of aluminum alloy; front panel and trim peaces are constructed of plastic; circuit boards are constructed of glass. |
| Finish type | Tektronix blue body and Tektronix silver-gray trim and front with black pouch, FDD feet, handle, and miscellaneous trim pieces |

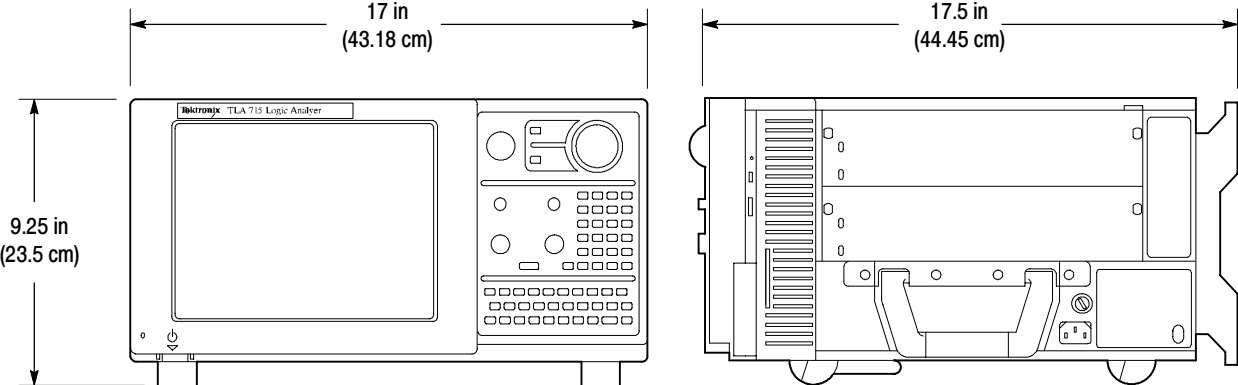

Figure 3: Dimensions of TLA715 portable mainframe

TLA714 Portable Mainframe Characteristics

Tables 44 through 51 describe the specifications for the TLA714 Portable Mainframe.

Table 44: TLA714 Internal controller

| Characteristic | Description |
|--|---|
| Operating System | Microsoft Windows |
| Microprocessor | Intel Pentium PC-AT configuration with a 266 MHz Intel Pentium MMX microprocessor |
| Main Memory | SDRAM |
| Style | 144 pin SO DIMM, 2 Sockets |
| Speed | 66 MHz |
| Installed Configurations | Minimum 64 MB loaded in one socket Maximum 128 MB with both sockets loaded |
| Cache Memory | 512 KB Level 2 (L2) write-back cache |
| Flash BIOS | 512 KB Provides PC plug-and-play services with and without Microsoft Windows operating system. Flash based BIOS field upgradable via a floppy disk. |
| Real-Time Clock and CMOS Setups NVRAM | Real-Time clock/calendar, with typical 10-year life. Standard and advanced PC CMOS setups. |
| Bootable Replaceable Hard Disk Drive | Standard PC compatible IDE (Integrated device Electronics) hard disk drive residing on an EIDE interface. |
| Size | Minimum 10 GByte Maximum 30 GByte Continually subject to change due to the fast-moving PC component environment. These storage capacities valid at product introduction. |
| Interface | ATA 4/Enhanced IDE (EIDE) |
| Average seek time | Read 13 ms |
| I/O data-transfer rate | 33.3 MB/s max (U-DMA mode 2) (ATA33) |
| CD-RW Drive | Standard PC compatible IDE (Integrated device Electronics) 8x-8x-24x CD-RW drive residing on an IDE interface Continually subject to change due to the fast-moving PC component environment |
| Floppy Disk Drive | Standard 3.5 inch 1.44-MB PC compatible high-density, double-sided floppy disk drive |

Table 45: TLA714 display system

| Characteristic | Description | | | | | | | | | | | | | | | | | | | | |
|--|---|---------------------|--------|-----------|-----|-----------|--------|-----------|------------|-----------|-----|-----------|--------|-----------|------------|------------|-----|-------------|-----|-------------|-----|
| Classification | Standard PC graphics accelerator technology (bitBLT-based); capable of supporting both internal color LCD display and external color SVGA/XGA monitor | | | | | | | | | | | | | | | | | | | | |
| Display Memory Size | DRAM-based frame-buffer memory 2 MB | | | | | | | | | | | | | | | | | | | | |
| Display Selection | Hardware sense of external SVGA monitor during BIOS boot sequence; defaults to internal color LCD display; automatically switches to external SVGA monitor, if attached Dual (simultaneous) display of external SVGA monitor and internal color LCD is possible via special "simulscan" CMOS setup, as long as internal and external displays operate at same resolution (limited to 800x600 on current TFT LCD) and display rates Dynamic Display Configuration (DDC2 A and B) support for external SVGA monitor is provided. | | | | | | | | | | | | | | | | | | | | |
| External Display Drive Display Size | One SVGA/XGA-compatible analog output port User selected via Microsoft Windows Plug and Play support for DDC1 and DDC2 A and B <table border="1"> <thead> <tr> <th>Resolution (Pixels)</th> <th>Colors</th> </tr> </thead> <tbody> <tr> <td>640 x 480</td> <td>256</td> </tr> <tr> <td>640 x 480</td> <td>64,000</td> </tr> <tr> <td>640 x 480</td> <td>16,800,000</td> </tr> <tr> <td>800 x 600</td> <td>256</td> </tr> <tr> <td>800 x 600</td> <td>64,000</td> </tr> <tr> <td>800 x 600</td> <td>16,800,000</td> </tr> <tr> <td>1024 x 768</td> <td>256</td> </tr> <tr> <td>1280 x 1024</td> <td>256</td> </tr> <tr> <td>1600 x 1200</td> <td>256</td> </tr> </tbody> </table> | Resolution (Pixels) | Colors | 640 x 480 | 256 | 640 x 480 | 64,000 | 640 x 480 | 16,800,000 | 800 x 600 | 256 | 800 x 600 | 64,000 | 800 x 600 | 16,800,000 | 1024 x 768 | 256 | 1280 x 1024 | 256 | 1600 x 1200 | 256 |
| Resolution (Pixels) | Colors | | | | | | | | | | | | | | | | | | | | |
| 640 x 480 | 256 | | | | | | | | | | | | | | | | | | | | |
| 640 x 480 | 64,000 | | | | | | | | | | | | | | | | | | | | |
| 640 x 480 | 16,800,000 | | | | | | | | | | | | | | | | | | | | |
| 800 x 600 | 256 | | | | | | | | | | | | | | | | | | | | |
| 800 x 600 | 64,000 | | | | | | | | | | | | | | | | | | | | |
| 800 x 600 | 16,800,000 | | | | | | | | | | | | | | | | | | | | |
| 1024 x 768 | 256 | | | | | | | | | | | | | | | | | | | | |
| 1280 x 1024 | 256 | | | | | | | | | | | | | | | | | | | | |
| 1600 x 1200 | 256 | | | | | | | | | | | | | | | | | | | | |
| Internal Display Classification | Thin Film Transistor (TFT) 10.4 inch active-matrix color LCD display; CCFL backlight; intensity controllable via software | | | | | | | | | | | | | | | | | | | | |
| Resolution | 800 x 600 pixels | | | | | | | | | | | | | | | | | | | | |
| Color Scale | 262,144 colors (6-bit RGB) | | | | | | | | | | | | | | | | | | | | |

Table 46: TLA714 front-panel interface

| Characteristic | Description |
|----------------------------|---|
| QWERTY Keypad | ASCII keypad to support naming of files, traces, and keyboard equivalents of pointing device inputs for menus |
| HEX Keypad | HEX keypad supporting text entry functions |
| Special Function Knobs | Various functions |
| Integrated Pointing Device | GlidePoint touchpad |
| Dual USB Ports | Two USB (Universal Serial Bus) compliant ports |
| Mouse Port | PS/2 compatible mouse port utilizing a mini DIN connector |
| Keyboard Port | PS/2 compatible keyboard port utilizing a mini DIN connector |

Table 47: TLA714 rear-panel interface

| Characteristic | Description |
|----------------------------------|---|
| Parallel Interface Port (LPT) | 36-pin high-density connector supports standard Centronics mode, Enhanced Parallel Port (EPP), or Microsoft high-speed mode (ECP) |
| Serial Interface Port (COM A) | 9-pin male sub-D connector to support RS-232 serial port |
| SVGA Output Port (SVGA OUT) | 15-pin sub-D SVGA connector |
| Type I and II PC Card Port | Standard Type I and II PC-compatible PC card slot |
| Type I, II, and III PC Card Port | Standard Type I, II, and III PC-compatible PC card slot |

Table 48: TLA714 AC power source

| Characteristic | Description |
|---|---|
| Source Voltage and Frequency | 90-250 V _{RMS} , 45-66 Hz, continuous range CAT II 100-132 V _{RMS} , 360-440 Hz, continuous range CAT II |
| Fuse Rating | |
| 90 V - 250 V Operation (159-0046-00) | UL198/CSA C22.2 0.25 in × 1.25 in, Fast Blow, 8 A, 250 V |
| 90 V - 250 V Operation (159-0381-00) | IEC 127/Sheet 1 5 mm × 20 mm, Fast Blow, 6.3 A, 250 V |
| Maximum Power Consumption | 600 W line power maximum |
| Steady-State Input Current | 6 A _{RMS} maximum |
| Inrush Surge Current | 70 A maximum |

Table 48: TLA714 AC power source (Cont.)

| Characteristic | Description |
|---------------------------------|--|
| Power Factor Correction | Yes |
| On/Standby Switch and Indicator | Front Panel On/Standby switch, with LED indicator located next to switch The power cord provides main power disconnect. |

Table 49: TLA714 secondary power

| Characteristic | Description | | | |
|--|-------------|----------|----------|----------|
| ✓ DC Voltage Regulation (Combined System, voltage available at each slot) | Voltage | Minimum | Nominal | Maximum |
| | +24 V | 23.28 V | 24.24 V | 25.20 V |
| | +12 V | 11.64 V | 12.12 V | 12.60 V |
| | +5 V | 4.875 V | 5.063 V | 5.250 V |
| | -2 V | -2.10 V | -2.00 V | -1.90 V |
| | -5.2 V | -5.460 V | -5.252 V | -5.044 V |
| | -12 V | -12.60 V | -12.12 V | -11.64 V |
| | -24 V | -25.20 V | -24.24 V | -23.28 V |

Table 50: TLA714 cooling

| Characteristic | Description |
|-------------------|--|
| Cooling System | Forced air circulation (negative pressurization) utilizing six fans operating in parallel |
| Cooling Clearance | 2 in (51 mm), sides and rear; unit should be operated on a flat, unobstructed surface |
| Slot Activation | Installing a module activates the cooling for the corresponding occupied slots by opening the air flow shutter mechanism. Optimizes cooling efficiency by only applying airflow to modules that are installed. |

Table 51: TLA714 mechanical

| Characteristic | Description |
|----------------------------------|---|
| Overall Dimensions | (See Figure 4 for overall chassis dimensions.) |
| Height (with feet) | 9.25 in (235 mm) |
| Width | 17.0 in (432 mm) |
| Depth | 17.5 in (445 mm) |
| Weight (Typical) | 30 lbs 12 oz. (13.9 kg) with no modules installed, 2 dual-wide slot covers, and empty pouch |
| Shipping configuration (Typical) | 88 lbs (26.3 kg) minimum configuration (no modules or probes), with all standard accessories 87 lb (39.5 kg) full configuration, with 2 TLA7P4 modules and standard accessories (including probes) |

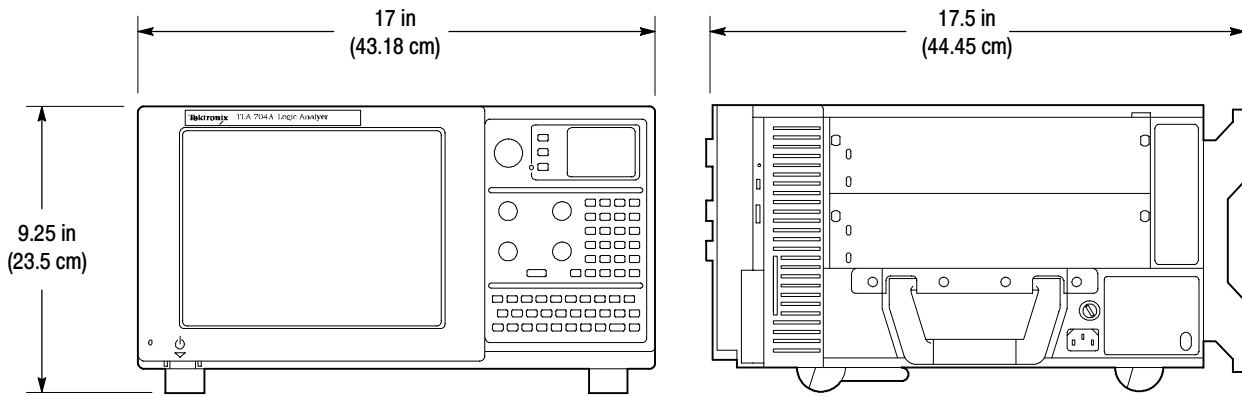

Figure 4: Dimensions of TLA714 portable mainframe

Benchtop and Expansion Mainframe Characteristics

Tables 52 through 56 list the specifications for the TLA720/721 Benchtop mainframe and the TLA7XM expansion mainframe.

Table 52: Benchtop and expansion mainframe AC power source

| Characteristic | Description |
|--|---|
| Source Voltage | 90-250 V _{RMS} , 45-66 Hz, continuous range CAT II 100-132 V _{RMS} , 360-440 Hz, continuous range CAT II |
| Maximum Power Consumption | 1450 W line power (the maximum power consumed by a fully loaded 13-slot instrument) |
| Fuse Rating (Current and voltage ratings and type of fuse used to fuse the source line voltage) | |
| 90 V - 132 VAC _{RMS} Operation High-power/Low Line (159-0379-00) | Safety: UL198G/CSA C22.2 Size: 0.25 in × 1.25 in Style: Slow acting Rating: 20 A/250 V |
| 103 V - 250 VAC _{RMS} Operation (159-0256-00) | Safety: UL198G/CSA C22.2 Size: 0.25 in × 1.25 in Style: No. 59/Fast acting Rating: 15 A/250 V |
| 207 V - 250 VAC _{RMS} Operation (159-0381-00) | Safety: IEC 127/Sheet 1 Size: 5 mm × 20 mm Style: Fast acting "F", high-breaking capacity Rating: 6.3 A/250 V |
| Inrush Surge Current | 70 A maximum |
| Steady State Input Current | 16.5 A _{RMS} maximum at 90 VAC _{RMS} 6.3 A _{RMS} maximum at 207 VAC _{RMS} |
| Power Factor Correction (Typical) | 0.99 at 60 Hz operation and 0.95 at 400 Hz operation |
| ON/Standby Switch and Indicator | Front Panel On/Standby switch with integral power indicator |

Table 53: Benchtop and expansion mainframe secondary power

| Characteristic | Description | | | |
|--|-------------|----------|----------|----------|
| ✓ DC Voltage Regulation (Combined System, voltage available at each slot) | Voltage | Minimum | Nominal | Maximum |
| | +24 V | 23.28 V | 24.24 V | 25.20 V |
| | +12 V | 11.64 V | 12.12 V | 12.60 V |
| | +5 V | 4.875 V | 5.063 V | 5.250 V |
| | -2 V | -2.10 V | -2.00 V | -1.90 V |
| | -5.2 V | -5.460 V | -5.252 V | -5.044 V |
| | -12 V | -12.60 V | -12.12 V | -11.64 V |
| | -24 V | -25.20 V | -24.24 V | -23.28 V |

Table 54: Benchtop and expansion mainframe cooling

| Characteristic | Description |
|-----------------------------------|--|
| Cooling system | Forced air circulation system (positive pressurization) using a single low-noise centripetal (squirrel cage) fan configuration with no filters for the power supply and 13 module slots. |
| Fan speed control | Rear panel switch selects between full speed and variable speed. Slot exhaust temperature and ambient air temperature are monitored such that a constant delta temperature is maintained. |
| Slot activation | Installing a module activates the cooling for the corresponding occupied slots by opening the air flow shutter mechanism. Optimizes cooling efficiency by only applying airflow to modules that are installed. |
| Pressurization | Positive pressurization system, all chambers including modules |
| Slot airflow direction | P2 to P1, bottom of module to top of module |
| Mainframe air intake | Lower fan-pack rear face and bottom |
| Mainframe air exhaust | Top-sides and top-rear back. Top rear-back exhaust redirected to the sides by the fan pack housing to minimize reentry into the intake. |
| Δ Temperature readout sensitivity | 100 mV/ °C with 0 °C corresponding to 0 V output |
| Temperature sense range | -10 °C to +90 °C, delta temperature ≤ 50 °C |
| Clearance | 2 in (51 mm), rear, top, and sides |
| Fan speed readout | $RPM = 20 \times (\text{Tach frequency})$ or $10 \div (+\text{Pulse Width})$ where (+Pulse Width) is the positive width of the TACH1 fan output signal measured in seconds |
| Fan speed range | 650 to 2250 RPM |

Table 55: Enhanced monitor

| Characteristic | Description |
|------------------------------------|--|
| Voltage readout | +24 V, -24 V, +12 V, -12 V, +5 V, -5.2 V, -2 V, +5 V _{Standby} if present, and +5 V _{External} via RS232 |
| Voltage readout accuracy (Typical) | ±3% maximum |
| Current readout | Readout of the present current on the +24 V, -24 V, +12 V, -12 V, +5 V, -2 V, -5.2 V rails via RS232 |
| Current readout accuracy (Typical) | ±5% of maximum power supply I_{mp} |
| Rear panel connector levels | ±25 VDC maximum, 1 A maximum per pin (Provides access for RS-232 host to enhanced monitor) |

Table 56: Benchtop and expansion mainframe mechanical

| Characteristic | Description |
|---|---|
| Overall Dimensions | (See Figures 5 and 6 for overall dimensions.) |
| Standard | |
| Height (with feet) | 13.7 in (346.7 mm) including feet |
| Width | 16.7 in (424.2 mm) |
| Depth | 26.5 in (673.1 mm) |
| Rackmount | |
| Height | 13.25 in (336.6 mm) |
| Width | 18.9 in (480.1 mm) |
| Depth | 28.9 in to 33.9 in (734.1 mm to 861.1 mm) in 0.5 in increments, user selectable |
| Benchtop controller dimensions | |
| Height | 10.32 in (262.1 mm) |
| Width | 2.39 in (60.7 mm) |
| Depth | 14.75 in (373.4 mm) |
| Expansion module dimensions | |
| Height | 10.32 in (262.1 mm) |
| Width | 1.25 in (31.75 mm) |
| Depth | 14.75 in (373.4 mm) |
| Weight | |
| Mainframe with benchtop controller and slot fillers (Typical) | 58 lbs 11 oz. (26.7 kg) |

Table 56: Benchtop and expansion mainframe mechanical (Cont.)

| Characteristic | Description |
|-------------------------------------|--|
| Shipping configuration (Typical) | 60 lbs 11 oz. (26.7 kg) minimum configuration with controller (only) and all standard accessories (two manuals, five dual-wide and one single-wide slot filler panels, power cord, empty pouch, front cover, keyboard, software, and cables) 187 lbs (85 kg) fully configured, same as above with the addition of five LA modules (four TLA7P4 modules, one TLA7N4 module) and all module standard accessories (probes and clips) |
| Benchtop controller | 6 lbs 10 oz. (3.0 kg) |
| Expansion module | 3 lbs (1.4 kg) |
| Maximum per slot | 5 lbs (2.27 kg) |
| Rackmount kit adder | 20 lbs (9.1 kg) |
| Size | |
| Benchtop controller | Three slots wide |
| Expansion module | Single slot wide |
| Acoustic noise level (Typical) | |
| Variable fan speed (at 860 RPM) | 43.2 dBA weighted (front) 43.8 dBA weighted (back) |
| Full speed fan (switched at rear) | 66.2 dBA weighted (front) 66.2 dBA weighted (back) |
| Construction materials | Chassis parts, aluminum alloy Front panel and trim pieces, plastic Circuit boards, glass laminate |
| Finish type | Mainframes are Tektronix silver gray with dark gray trim on fan pack and bottom feet support rails. Benchtop controllers are Tektronix silver gray on front lexan and injector/ejector assemblies with a black FDD and PC card ejector buttons. |

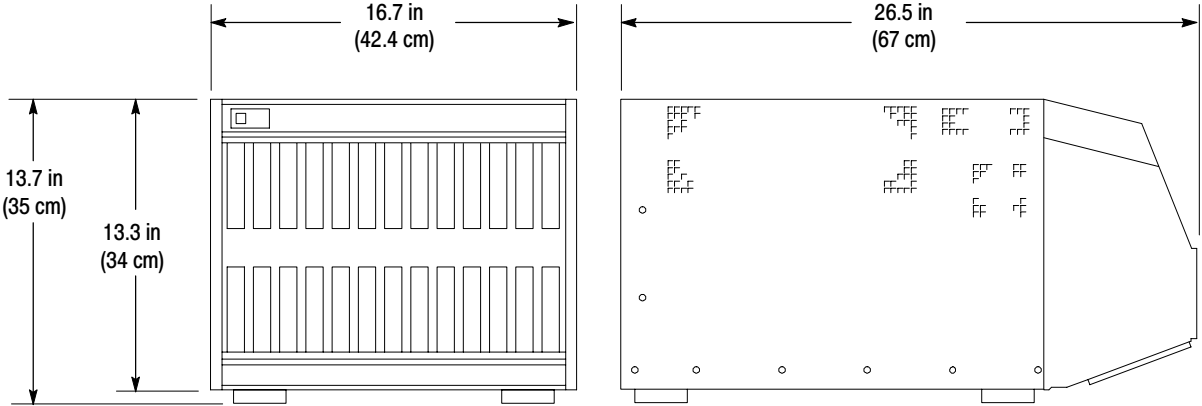

Figure 5: Dimensions of the benchtop and expansion mainframe

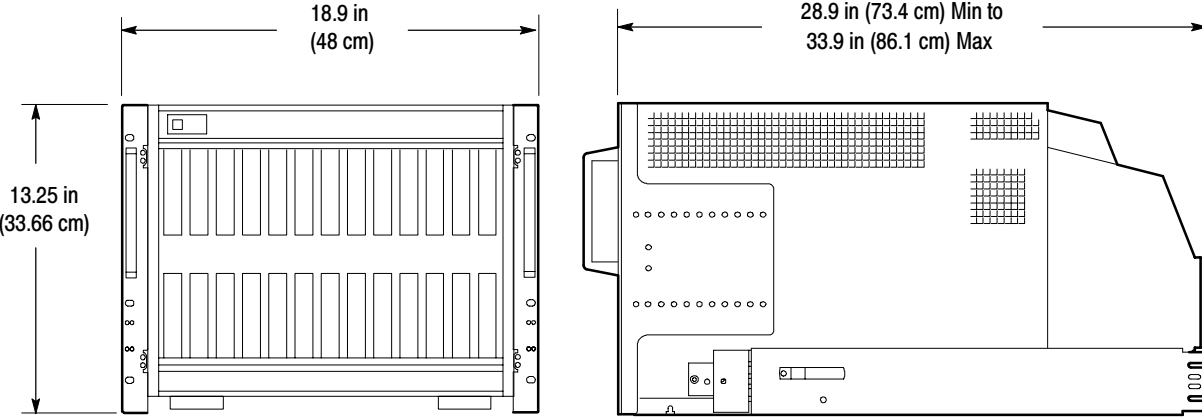

Figure 6: Dimensions of the benchtop and expansion mainframe with rackmount option

TLA721 Dual Monitor Benchtop Controller Characteristics

Tables 57 and 58 lists the specifications for the TLA721 Dual Monitor Benchtop Controller.

Table 57: TLA721 benchtop controller characteristics

| Characteristic | Description |
|---|--|
| Operating system | Microsoft Windows 2000 |
| Microprocessor | Intel 733 MHz Pentium III configuration with an Intel 815E chip-set |
| Main memory | Two 144 pin SODIMM sockets support one or two SDRAM modules. |
| Available configurations | 16, 32, 64, 256 MB per SODIMM |
| Installed configuration | 512 MB maximum configuration |
| Speed | 133 MHz |
| CAS latency | 2, 3 |
| RAS to CAS delay | 2, 3 |
| RAS precharge | 2, 3 |
| DRAM cycle time | 5/7 or 7/9 |
| Cache memory | 512 KB, level 2 (L2) write-back cache |
| Flash BIOS | 512 KB Provides PC plug-and-play services with and without Microsoft Windows operating system. Flash based BIOS field upgradable via a floppy disk Forced recovery jumper is provided |
| Real-time clock and CMOS setups NVRAM | Real-time clock/calendar. Standard and advanced PC CMOS setups: see BIOS specifications |
| RTC, CMOS setup, & PnP NVRAM retention time (Typical) | Battery life is typically > 7 years |
| Floppy disk drive | Standard 3.5 inch, 1.44 MB, high-density, double-sided, PC-compatible high-density floppy disk drive |
| Transfer rate | 500 Kbits per second |
| Access time (ave.) | 194 ms |
| Bootable replaceable hard disk drive | Standard PC compatible IDE (Integrated device Electronics) hard disk drive residing on an EIDE interface |
| Size | 40 GByte Continually subject to change due to the fast-moving PC component environment. These storage capacities valid at product introduction. |
| Interface | ATA-5/Enhanced IDE (EIDE) |

Table 57: TLA721 benchtop controller characteristics (Cont.)

| Characteristic | Description |
|--------------------------------------|--|
| Average seek time | Read 12 ms |
| I/O data-transfer rate | 33.3 MB/s maximum (U-DMA mode 2) |
| Average latency | 7/14 ms |
| Cache buffer | 512 KB |
| CD-RW Drive | Standard PC compatible IDE (Integrated device Electronics) 8x-8x-24x CD-RW drive residing on an IDE interface. Continually subject to change due to the fast-moving PC component environment. |
| Applicable formats | CD-DA; CE-ROM Mode 1, Mode 2; CD-ROM XA Mode 2 (Form 1, Form 2); Photo CD (single/multi session); Enhanced CD |
| Interface | IDE (ATAPI) |
| Average access time | 130 ms |
| Data-transfer rate (burst sustained) | 16.7 MB per second maximum, 1290-3000 KB per second |

Table 57: TLA721 benchtop controller characteristics (Cont.)

| Characteristic | Description | | | | | | | | | | | | | | | | | | | | | | | | | | | | | | | | | | | | | | | | | | | | | | | | | | | |
|------------------------|--|---------------------|--------|---------------|-----------|-----------|--------|------------|--|--|-----------|-----------|--------|------------|--|--|------------|-------------------|------------|-------------|-------------------|----|------------|-----------|----|-------------|-----------|----|---------------------|--------|---------------|-----------|-----------|--------|------------|--|--|-----------|-----------|--------|------------|--|--|------------|-------------------|------------|-------------|-------------------|------------|-------------|-----|--------|
| Display classification | Standard PC graphics accelerator technology (bitBLT based) residing on the Peripheral Component Interconnect (PCI) bus capable of supporting external color VGA, SVGA, or XGA monitors | | | | | | | | | | | | | | | | | | | | | | | | | | | | | | | | | | | | | | | | | | | | | | | | | | | |
| Display configuration | Hardware automatically senses a missing flat panel LCD in the benchtop mainframe and defaults to the external SVGA monitor output during the BIOS boot sequence (no internal TFT LCD display exists). This is indicated by a single beep during the boot sequence. Dynamic Display Configuration 1 (DDC1) support for the external monitor is provided. | | | | | | | | | | | | | | | | | | | | | | | | | | | | | | | | | | | | | | | | | | | | | | | | | | | |
| Display memory | 4 MB SDRAM is on board the video controller; no external video memory | | | | | | | | | | | | | | | | | | | | | | | | | | | | | | | | | | | | | | | | | | | | | | | | | | | |
| Display drive | Two VGA, SVGA, or XGA compatible analog output ports | | | | | | | | | | | | | | | | | | | | | | | | | | | | | | | | | | | | | | | | | | | | | | | | | | | |
| Display size | User selected via Microsoft Windows Plug and Play support for DDC1 and DDC2 A and B (Primary video port with Silicon Motion Chip) <table border="0"> <thead> <tr> <th>Resolution (Pixels)</th> <th>Colors</th> <th>Refresh Rates</th> </tr> </thead> <tbody> <tr> <td>640 x 480</td> <td>256, 64 K</td> <td>16.8 M</td> </tr> <tr> <td>60, 75, 85</td> <td></td> <td></td> </tr> <tr> <td>800 x 600</td> <td>256, 64 K</td> <td>16.8 M</td> </tr> <tr> <td>60, 75, 85</td> <td></td> <td></td> </tr> <tr> <td>1024 x 768</td> <td>256, 64 K, 16.8 M</td> <td>60, 75, 85</td> </tr> <tr> <td>1280 x 1024</td> <td>256, 64 K, 16.8 M</td> <td>60</td> </tr> <tr> <td>1600 x 600</td> <td>256, 64 K</td> <td>60</td> </tr> <tr> <td>1600 x 1200</td> <td>256, 64 K</td> <td>60</td> </tr> </tbody> </table> (Secondary video port with 815E Chip set) <table border="0"> <thead> <tr> <th>Resolution (Pixels)</th> <th>Colors</th> <th>Refresh Rates</th> </tr> </thead> <tbody> <tr> <td>640 x 480</td> <td>256, 64 K</td> <td>16.8 M</td> </tr> <tr> <td>60, 75, 85</td> <td></td> <td></td> </tr> <tr> <td>800 x 600</td> <td>256, 64 K</td> <td>16.8 M</td> </tr> <tr> <td>60, 75, 85</td> <td></td> <td></td> </tr> <tr> <td>1024 x 768</td> <td>256, 64 K, 16.8 M</td> <td>60, 75, 85</td> </tr> <tr> <td>1280 x 1024</td> <td>256, 64 K, 16.8 M</td> <td>60, 75, 85</td> </tr> <tr> <td>1600 x 1200</td> <td>256</td> <td>60, 75</td> </tr> </tbody> </table> | Resolution (Pixels) | Colors | Refresh Rates | 640 x 480 | 256, 64 K | 16.8 M | 60, 75, 85 | | | 800 x 600 | 256, 64 K | 16.8 M | 60, 75, 85 | | | 1024 x 768 | 256, 64 K, 16.8 M | 60, 75, 85 | 1280 x 1024 | 256, 64 K, 16.8 M | 60 | 1600 x 600 | 256, 64 K | 60 | 1600 x 1200 | 256, 64 K | 60 | Resolution (Pixels) | Colors | Refresh Rates | 640 x 480 | 256, 64 K | 16.8 M | 60, 75, 85 | | | 800 x 600 | 256, 64 K | 16.8 M | 60, 75, 85 | | | 1024 x 768 | 256, 64 K, 16.8 M | 60, 75, 85 | 1280 x 1024 | 256, 64 K, 16.8 M | 60, 75, 85 | 1600 x 1200 | 256 | 60, 75 |
| Resolution (Pixels) | Colors | Refresh Rates | | | | | | | | | | | | | | | | | | | | | | | | | | | | | | | | | | | | | | | | | | | | | | | | | | |
| 640 x 480 | 256, 64 K | 16.8 M | | | | | | | | | | | | | | | | | | | | | | | | | | | | | | | | | | | | | | | | | | | | | | | | | | |
| 60, 75, 85 | | | | | | | | | | | | | | | | | | | | | | | | | | | | | | | | | | | | | | | | | | | | | | | | | | | | |
| 800 x 600 | 256, 64 K | 16.8 M | | | | | | | | | | | | | | | | | | | | | | | | | | | | | | | | | | | | | | | | | | | | | | | | | | |
| 60, 75, 85 | | | | | | | | | | | | | | | | | | | | | | | | | | | | | | | | | | | | | | | | | | | | | | | | | | | | |
| 1024 x 768 | 256, 64 K, 16.8 M | 60, 75, 85 | | | | | | | | | | | | | | | | | | | | | | | | | | | | | | | | | | | | | | | | | | | | | | | | | | |
| 1280 x 1024 | 256, 64 K, 16.8 M | 60 | | | | | | | | | | | | | | | | | | | | | | | | | | | | | | | | | | | | | | | | | | | | | | | | | | |
| 1600 x 600 | 256, 64 K | 60 | | | | | | | | | | | | | | | | | | | | | | | | | | | | | | | | | | | | | | | | | | | | | | | | | | |
| 1600 x 1200 | 256, 64 K | 60 | | | | | | | | | | | | | | | | | | | | | | | | | | | | | | | | | | | | | | | | | | | | | | | | | | |
| Resolution (Pixels) | Colors | Refresh Rates | | | | | | | | | | | | | | | | | | | | | | | | | | | | | | | | | | | | | | | | | | | | | | | | | | |
| 640 x 480 | 256, 64 K | 16.8 M | | | | | | | | | | | | | | | | | | | | | | | | | | | | | | | | | | | | | | | | | | | | | | | | | | |
| 60, 75, 85 | | | | | | | | | | | | | | | | | | | | | | | | | | | | | | | | | | | | | | | | | | | | | | | | | | | | |
| 800 x 600 | 256, 64 K | 16.8 M | | | | | | | | | | | | | | | | | | | | | | | | | | | | | | | | | | | | | | | | | | | | | | | | | | |
| 60, 75, 85 | | | | | | | | | | | | | | | | | | | | | | | | | | | | | | | | | | | | | | | | | | | | | | | | | | | | |
| 1024 x 768 | 256, 64 K, 16.8 M | 60, 75, 85 | | | | | | | | | | | | | | | | | | | | | | | | | | | | | | | | | | | | | | | | | | | | | | | | | | |
| 1280 x 1024 | 256, 64 K, 16.8 M | 60, 75, 85 | | | | | | | | | | | | | | | | | | | | | | | | | | | | | | | | | | | | | | | | | | | | | | | | | | |
| 1600 x 1200 | 256 | 60, 75 | | | | | | | | | | | | | | | | | | | | | | | | | | | | | | | | | | | | | | | | | | | | | | | | | | |

Table 58: Front panel characteristics

| Characteristic | Description |
|-------------------------|---|
| SVGA output port (SVGA) | Two 15-pin sub-D SVGA connectors |
| Dual USB ports | Two USB (Universal Serial Bus) compliant ports |
| Mouse port | Front panel mounted PS2 compatible mouse port utilizing a mini DIN connector |
| Keyboard port | Front panel mounted PS2 compatible keyboard port utilizing a mini DIN connector |

Table 58: Front panel characteristics (Cont.)

| Characteristic | Description |
|----------------------------------|---|
| Parallel interface port (LPT) | 36-pin high-density connector supports standard Centronics mode, Enhanced Parallel Port (EPP), or Microsoft high-speed mode (ECP) |
| Serial interface port (COM) | 9-pin male sub-D connector to support an RS232 serial port |
| PC CardBus32 port | Standard Type I and II PC compatible PC card slot |
| Type I, II, and III PC Card Port | Standard Type I, II, and III PC compatible PC card slot |

TLA720 Benchtop Controller Characteristics

Tables 59 through 60 list the specifications for the TLA720 Benchtop Controller.

Table 59: TLA720 benchtop controller characteristics

| Characteristic | Description |
|---|--|
| Operating System | Microsoft Windows |
| Microprocessor | Intel Pentium 266 MHz PC-AT configuration with an Intel chip-set |
| Main Memory | SDRAM |
| Style | Two 144 pin SODIMM sockets support one or two SDRAM modules. |
| Installed Configuration | 128 MB Two 64 MB SDRAM modules installed |
| Speed | 60 ns |
| Cache Memory | 256 K, level 2 (L2) write-back cache |
| Flash BIOS | 512 KB Provides PC plug-and-play services with and without Microsoft Windows operating system. Flash based BIOS field upgradable via a floppy disk |
| Real-Time Clock and CMOS Setups NVRAM (Typical) | Real-time clock/calendar, with typical 7-year life. Standard and advanced PC CMOS setups: see BIOS specification. |
| Floppy Disk Drive | Standard 3.5 inch, 1.44 MB, double-sided, PC-compatible high-density floppy disk drive |
| Bootable Replaceable Hard Disk Drive | Standard PC compatible IDE (Integrated device Electronics) hard disk drive residing on an EIDE interface |
| Size | Maximum 30 GByte Continually subject to change due to the fast-moving PC component environment. These storage capacities valid at product introduction. |
| Interface | ATA-4/Enhanced IDE (EIDE) |
| Average seek time | Read 13 ms |
| I/O data-transfer rate | 33.3 MB/s maximum (U-DMA mode 2) |
| CD-RW Drive | Standard PC compatible IDE (Integrated device Electronics) 8x-8x-24x CD-RW drive residing on an IDE interface. Continually subject to change due to the fast-moving PC component environment. |

Table 59: TLA720 benchtop controller characteristics (Cont.)

| Characteristic | Description | | | | | | | | | | | | | | | | | | | | |
|----------------------------------|---|---------------------|--------|-----------|-----|-----------|--------|-----------|------------|-----------|-----|-----------|--------|-----------|------------|------------|-----|-------------|-----|-------------|-----|
| Display Classification | Standard PC graphics accelerator technology (bitBLT based) capable of driving external color VGA, SVGA, or XGA monitors | | | | | | | | | | | | | | | | | | | | |
| Display Memory | DRAM based frame-buffer memory | | | | | | | | | | | | | | | | | | | | |
| Size | 2 MB | | | | | | | | | | | | | | | | | | | | |
| Display Drive | One VGA, SVGA, or XGA compatible analog output port | | | | | | | | | | | | | | | | | | | | |
| Display Size | User selected via Microsoft Windows Plug and Play support for DDC1 and DDC2 A and B <table border="0"> <thead> <tr> <th>Resolution (Pixels)</th> <th>Colors</th> </tr> </thead> <tbody> <tr> <td>640 x 480</td> <td>256</td> </tr> <tr> <td>640 x 480</td> <td>64,000</td> </tr> <tr> <td>640 x 480</td> <td>16,800,000</td> </tr> <tr> <td>800 x 600</td> <td>256</td> </tr> <tr> <td>800 x 600</td> <td>64,000</td> </tr> <tr> <td>800 x 600</td> <td>16,800,000</td> </tr> <tr> <td>1024 x 768</td> <td>256</td> </tr> <tr> <td>1280 x 1024</td> <td>256</td> </tr> <tr> <td>1600 x 1200</td> <td>256</td> </tr> </tbody> </table> | Resolution (Pixels) | Colors | 640 x 480 | 256 | 640 x 480 | 64,000 | 640 x 480 | 16,800,000 | 800 x 600 | 256 | 800 x 600 | 64,000 | 800 x 600 | 16,800,000 | 1024 x 768 | 256 | 1280 x 1024 | 256 | 1600 x 1200 | 256 |
| Resolution (Pixels) | Colors | | | | | | | | | | | | | | | | | | | | |
| 640 x 480 | 256 | | | | | | | | | | | | | | | | | | | | |
| 640 x 480 | 64,000 | | | | | | | | | | | | | | | | | | | | |
| 640 x 480 | 16,800,000 | | | | | | | | | | | | | | | | | | | | |
| 800 x 600 | 256 | | | | | | | | | | | | | | | | | | | | |
| 800 x 600 | 64,000 | | | | | | | | | | | | | | | | | | | | |
| 800 x 600 | 16,800,000 | | | | | | | | | | | | | | | | | | | | |
| 1024 x 768 | 256 | | | | | | | | | | | | | | | | | | | | |
| 1280 x 1024 | 256 | | | | | | | | | | | | | | | | | | | | |
| 1600 x 1200 | 256 | | | | | | | | | | | | | | | | | | | | |
| SVGA Output Port (SVGA) | The SVGA port utilizing a 15-pin sub-D SVGA connector | | | | | | | | | | | | | | | | | | | | |
| Dual USB Ports | Two USB (Universal Serial Bus) compliant ports | | | | | | | | | | | | | | | | | | | | |
| Mouse Port | Front panel mounted PS2 compatible mouse port utilizing a mini DIN connector | | | | | | | | | | | | | | | | | | | | |
| Keyboard Port | Front panel mounted PS2 compatible keyboard port utilizing a mini DIN connector | | | | | | | | | | | | | | | | | | | | |
| Parallel Interface Port (LPT) | 36-pin high-density connector supports standard Centronics mode, Enhanced Parallel Port (EPP), or Microsoft high-speed mode (ECP) | | | | | | | | | | | | | | | | | | | | |
| Serial Interface Port (COM) | 9-pin male sub-D connector to support an RS232 serial port | | | | | | | | | | | | | | | | | | | | |
| Type I and II PC Card Port | Standard Type I and II PC compatible PC card slot | | | | | | | | | | | | | | | | | | | | |
| Type I, II, and III PC Card Port | Standard Type I, II, and III PC compatible PC card slot | | | | | | | | | | | | | | | | | | | | |

Table 60: TLA720 benchtop controller mechanical characteristics

| Characteristic | Description |
|---------------------------|-----------------------|
| Weight (<i>Typical</i>) | 6 lb. 10 oz. (2.9 kg) |
| Size | Three slots wide |
| Overall dimensions | |
| Height | 10.32 in (262 mm) |
| Width | 3.6 in (83 mm) |
| Depth | 14.7 in (373 mm) |

TLA7Axx Series Logic Analyzer Module Characteristics

Tables 61 through 69 list the specifications of the TLA7Axx Series Logic Analyzer modules.

Table 61: TLA7Axx input parameters (with probes)

| Characteristic | Description |
|---|---|
| ✓ Threshold accuracy (Certifiable parameter) | $\pm (35 \text{ mV} + 1\% \text{ of the threshold voltage setting})$ |
| Threshold range and step size | Setable from +4.5 V to -2.0 V in 5 mV steps |
| Threshold channel selection | 16 threshold groups assigned to channels. Each probe has four threshold settings, one for each of the clock/qualifier channels and one per group of 16 data channels. |
| ✓ Channel to channel skew | $\leq 400 \text{ ps}$ When merged, add the following for slave modules: 0.0 ns when data is acquired on the slave modules through local clocks 125 ps when data is acquired on the slave modules via the master modules' clock and merge deskew has been performed. 375 ps when data is acquired on the slave modules via the master module's clock and merge deskew has <i>NOT</i> been performed. |
| Channel to channel skew (Typical) | $\leq 300 \text{ ps}$ When merged, add the following for slave modules: 0.0 ns when data is acquired on the slave modules through local clocks 125 ps when data is acquired on the slave modules via the master modules' clock and merge deskew has been performed. 375 ps when data is acquired on the slave modules via the master module's clock and merge deskew has <i>NOT</i> been performed. |
| Sample uncertainty | |
| Asynchronous | Sample period |
| Synchronous | 125 ps |
| Minimum slew rate (Typical) | 0.2 V/ns |
| Input voltage range | -2.5 V to +5 V |
| Maximum operating voltage swing | 6.0 V peak-to-peak |
| Probe overdrive | |
| Single ended probes | $\pm 150 \text{ mV}$ or $\pm 25\%$ of signal swing minimum required beyond threshold, whichever one is greater |
| Differential probes | $V_{\text{pos}} - V_{\text{neg}}$ is $\geq 150\text{mV}_{\text{p-p}}$ |
| Maximum nondestructive input signal to probe | $\pm 15 \text{ V}$ |
| Minimum input pulse width (single channel) (Typical) | |
| P6860 and P6880 probes | 500 ps |
| P6810 probes | 750 ps |

Table 61: TLA7Axx input parameters (with probes) (Cont.)

| Characteristic | Description |
|---|--------------------|
| Delay time from probe tip to input probe connector (<i>Typical</i>) | |
| P6860 and P6880 probes | 7.7 ns \pm 80 ps |
| P6810 probes | 7.7 ns \pm 60 ps |

Table 62: Analog output

| Characteristic | Description |
|--------------------------------------|---|
| Number of outputs | Four analog outputs regardless of the module channel width. Any four of the module's channels can be mapped to the four analog outputs. |
| Attenuation | 10X mode for normal operation 5X mode for small signals (-1.5 V to +2.5 V) |
| Bandwidth (Typical) | 2 GHz |
| Accuracy (gain and offset) (Typical) | \pm (50 mV + 2% of signal amplitude) |

Table 63: Channel width and depth

| Characteristic | Description |
|--------------------------|-----------------------------|
| Number of channels | |
| TLA7AA4, TLA7AB4 | 128 data, 8 clock/qualifier |
| TLA7AA3 | 96 data, 6 clock/qualifier |
| TLA7AA2, TLA7AB2 | 64 data, 4 clock/qualifier |
| TLA7AA1 | 32 data, 2 clock/qualifier |
| Acquisition memory depth | |
| TLA7AAx series | 32 M per channel, maximum |
| TLA7ABx series | 64 M per channel, maximum |

Table 64: Clocking

| Characteristic | Description | |
|---|--|--------------------|
| Asynchronous clocking | | |
| ✓ Internal sampling period | 500 ps to 50 ms in a 1-2-5 sequence. Storage control can be used to only store data when it has changed (transitional storage) | |
| | 2 ns minimum for all channels 1 ns minimum for half channels (using 2:1 Demultiplex mode) 0.5 ns minimum for quarter channels (using 4:1 Demultiplex mode) | |
| ✓ Minimum recognizable word ¹ (across all channels) | Channel-to-channel skew + sample uncertainty Example for a P6860 high-density probe and a 2 ns sample period: 400 ps + 2 ns = 2.4 ns | |
| Synchronous clocking | | |
| Master clock channels ² | Product | Clock channels |
| | 32+2 module | 2 |
| | 64+4 module | 4 |
| | 96+6 module | 4 |
| | 128+8 module | 4 |
| Merged slave clock channels ² (64+4 channel modules and 32+2 channel modules cannot be merged.) | Product | Clock channels |
| | 96+6 module | 4 |
| | 128+8 module | 4 |
| Qualifier channels ³ | Product | Qualifier channels |
| | 32+2 module | 0 |
| | 64+4 module | 0 |
| | 96+6 module | 2 |
| | 128+8 module | 4 |
| Single channel setup and hold window size (Typical) | 500 ps | |
| ✓ Single module setup and hold window size (data and qualifiers) | Maximum window size = Maximum channel-to-channel skew + (2 x sample uncertainty) + 100 ps Maximum setup time = User interface setup time + 75 ps Maximum hold time = User interface hold time + 50 ps Example using P6810, P6860, or P6880 probe and user interface setup and hold of 625/0 typical: Maximum window size = 400 ps + 250 ps + 100 ps = 750 ps Maximum setup time = 625 ps + 75 ps = 700 ps Maximum hold time = 0.0 ps + 50 ps = 50 ps | |
| Single module setup and hold window size (data and qualifiers) (Typical) | Typical window size = Typical channel-to-channel skew + (2 x sample uncertainty) + 75 ps Example using P6860 probe: 300 ps + 250 ps + 75 ps = 625 ps | |

Table 64: Clocking (Cont.)

| Characteristic | Description |
|--|---|
| Merged module setup and hold window size (data and qualifiers) (Typical) | <p>Maximum window size = Single module setup and hold + merge skew</p> <p>When determining the required setup and hold window for merged modules, take into consideration if the slave module's local clocks re used to acquire data and if a merge deskew has been performed. If the slave module uses its own clocks to acquire data, then the typical and maximum setup and hold values are the same as a stand-alone module (the same is true for the master module itself). The only time the additional merge skew values apply is when the clocks on the master module acquire data on the slave modules.</p> <p>When a slave module acquires data using its own local clocks, merge skew = 0 ps When a slave module acquires data using clocks from the master module <i>without</i> merge deskew, merge skew = 375 ps When a slave module acquires data using clocks from the master module and <i>has</i> had merge deskew performed, merge skew = 125 ps.</p> <p>Example using P6810, P6860, or P6880 probe with slave module acquiring data via clocks from the master module <i>without</i> merge deskew: Maximum window size = 750 ps + 375 ps = 1.125 ns Typical window size = 625 ps + 375 ps = 1.000 ns</p> <p>The user interface setup and hold window for merge applications is affected as follows by merge skew: Typical setup time = User interface setup time + (merge skew/2) Typical hold time = User interface hold time + (merge skew/2) Maximum setup time = User interface setup time + 75 ps + (merge skew/2) Maximum hold time = User interface hold time + 50 ps + (merge skew/2)</p> <p>Example using P6810, P6860, or P6880 probe, with user interface default setup and hold time of 625/0 typical, and merge configuration that <i>has</i> had merge deskew performed: Typical setup time = 625 ps + (125 ps/2) = 688 ps Typical hold time = 0 ps + (125 ps/2) = 62 ps Maximum setup time = 625 ps + 75 ps + (125 ps/2) = 763 ps Maximum hold time = 0 ps + 50 ps + (125 ps/2) = 112 ps</p> |
| Setup and hold window range | <p>For each channel, the setup and hold window can be moved from +8.0 ns (T_s typical) to -8.0 ns (T_s typical) in 0.125 ns steps (setup time).</p> <p>The setup and hold window can be shifted toward the setup region by 0 ns, 4 ns, or 8 ns. With a 0 ns shift, the range is +8 ns to -8 ns; with a 4 ns shift, the range is +12 ns to -4 ns; with an 8 ns shift, the range is +16 ns to 0 ns. The sample point selection region is the same setup and hold window. Setup times are specified as typical figures. Hold time follows the setup time by the setup and hold window size.</p> |
| ✓ Maximum synchronous clock rate | <p>450 MHz in full-speed mode (2.2 ns minimum between active clock edges)</p> <p>235 MHz in half-speed mode (4.25 ns minimum between active clock edges)</p> <p>120 MHz in quarter-speed mode (8.3 ns minimum between active clock edges)</p> <p>800 MHz on half channels⁴</p> <p>Software controls the selection between full-speed and half-speed modes.</p> |

Table 64: Clocking (Cont.)

| Characteristic | Description |
|---|---|
| Demultiplex clocking (two clock edges required) | |
| Demultiplex channels (2:1) TLA7AA3, TLA7AA4, TLA7AB4 modules | Any individual channel can be demultiplexed with its partner channel. If multiplexing is enabled, all of the A and D channels are multiplexed; there is no individual selection. Channels demultiplex as follows: A3(7:0) to/from D3(7:0) A2(7:0) to/from D2(7:0) A1(7:0) to/from D1(7:0) A0(7:0) to/from D0(7:0) |
| TLA7AA1, TLA7AA2, TLA7AB2 modules | Any individual channel can be demultiplexed with its partner channel. If multiplexing is enabled, all of the A and D channels are multiplexed; there is no individual selection. Channels demultiplex as follows: A3(7:0) to/from C3(7:0) A2(7:0) to/from C2(7:0) A1(7:0) to/from D1(7:0) 64+4 modules only A0(7:0) to/from D0(7:0) 64+4 modules only |
| Demultiplex channels (4:1) TLA7AA3, TLA7AA4, TLA7AB4 modules | Unlike the 2:1 Demultiplex, the channels within a group of four cannot arbitrarily drive the others. E3(7:0) to E2(7:0), E1(7:0), E0(7:0) 128+8 modules only A3(7:0) to A2(7:0), D3(7:0), D2(7:0) A1(7:0) to A0(7:0), D1(7:0), D0(7:0) C3(7:0) to C2(7:0), C1(7:0), C0(7:0) CK3 to CK2, Q3, Q2 128+8 modules only CK1 to CK0, Q1, Q0 |
| TLA7AA1, TLA7AA2, TLA7AB2 modules | Unlike the 2:1 Demultiplex, the channels within a group of four cannot arbitrarily drive the others. A1(7:0) to A0(7:0), D1(7:0), D0(7:0) 64+4 modules only C3(7:0) to C2(7:0), A3(7:0), A2(7:0) |
| Time between Demultiplex clock edges (Typical) | Same limitations as normal synchronous acquisition |

Table 64: Clocking (Cont.)

| Characteristic | Description |
|---|--|
| Source synchronous clocking | |
| Clocks per module | Four |
| Clocks with merged modules | When merged, the slave modules have two clocks available from the master module. Including the local clocks, the total is six clocks. |
| Clock groups | Four for a single module and for a merged system |
| Size of clock group valid FIFO | Four stages when operated at 235 MHz or below (three stages when operated above 235 MHz); this allows four (source synchronous or other) clocks to occur before the clock that completes the Clock Group Valid signal for that group. |
| Source synchronous clock alignment window | Channel-to-channel skew only |
| Source synchronous clock reset | <p>The Clock Group Valid FIFO can be reset in one of the two ways:</p> <ol style="list-style-type: none"> 1. By the overflow of a presettable (0-255) 8-bit counter that counts one of the following clocks: 2 ns Clock or the master “heartbeat” clock (synchronous or asynchronous). An active edge places the reset count to its preset value. An active clock edge will clear the Clock Group Valid reset before the clock gets to the FIFO so that no data is lost. 2. By enabling an external reset. In this mode, one of the clock channels must be traded on the master module to act as a level-sensitive reset input. Any one of the clocks can be selected. A polarity selection is available. This mode affects all Clock Group Complete circuits. <p>Neither one of the above modes can be intermixed; one or the other must be selected.</p> |
| Clocking state machine | |
| Pipeline delays | Channel groups can be programmed with a pipeline delay of 0 through 7 active clock changes. |

- 1 Specification only applies with asynchronous (internal) clocking. With synchronous clocking, the setup and hold window size applies.**
- 2 Any or all clock channels can be enabled. For an enabled clock channel, either the rising, falling, or both edges can be selected as active clock edges. Clock channels are stored.**
- 3 Qualifier channels are stored.**
- 4 This is a special mode and has some limitations such as the clocking state machine and trigger state machine only running at 500 MHz.**

Table 65: TLA7Axx module trigger system

| Characteristic | Description | | | | | | | | | | |
|--|---|---------------------------|---------------------|---------------------------|--------------------|------------------------------|---------------------|--------------------|---------------------|--------------------|---------------------|
| Trigger resources | | | | | | | | | | | |
| Word recognizers and range recognizers | <p>16, word recognizers can be combined to form full width, double bounded range recognizers. The following selections are available:</p> <table border="0"> <tr> <td>16 word recognizers</td> <td>0 range recognizers</td> </tr> <tr> <td>13 word recognizers</td> <td>1 range recognizer</td> </tr> <tr> <td>10 word recognizers</td> <td>2 range recognizers</td> </tr> <tr> <td>7 word recognizers</td> <td>3 range recognizers</td> </tr> <tr> <td>4 word recognizers</td> <td>4 range recognizers</td> </tr> </table> | 16 word recognizers | 0 range recognizers | 13 word recognizers | 1 range recognizer | 10 word recognizers | 2 range recognizers | 7 word recognizers | 3 range recognizers | 4 word recognizers | 4 range recognizers |
| 16 word recognizers | 0 range recognizers | | | | | | | | | | |
| 13 word recognizers | 1 range recognizer | | | | | | | | | | |
| 10 word recognizers | 2 range recognizers | | | | | | | | | | |
| 7 word recognizers | 3 range recognizers | | | | | | | | | | |
| 4 word recognizers | 4 range recognizers | | | | | | | | | | |
| Range recognizer channel order | <p>From most-significant probe group to least-significant probe group:</p> <p>C3 C2 C1 C0 E3 E2 E1 E0 A3 A2 D3 D2 A1 A0 D1 D0 Q3 Q2 Q1 Q0 CK3 CK2 Ck1 CK0</p> <p>Missing channels for modules with fewer than 136 channels are omitted. When merged, the range recognition extends across the modules. The master module contains the most-significant groups.</p> | | | | | | | | | | |
| Glitch detector (normal asynchronous clock mode) | <p>Channel groups can be enabled to detect glitches.</p> <p>Glitches are subject to pulse width variations of up to ± 125 ps</p> | | | | | | | | | | |
| Minimum detectable glitch pulse width (Typical) | <p>Minimum input pulse width (single channel)</p> <table border="0"> <tr> <td>P6860 high density probe:</td> <td>500 ps</td> </tr> <tr> <td>P6880 differential probe:</td> <td>500 ps</td> </tr> <tr> <td>P6810 general purpose probe:</td> <td>750 ps</td> </tr> </table> | P6860 high density probe: | 500 ps | P6880 differential probe: | 500 ps | P6810 general purpose probe: | 750 ps | | | | |
| P6860 high density probe: | 500 ps | | | | | | | | | | |
| P6880 differential probe: | 500 ps | | | | | | | | | | |
| P6810 general purpose probe: | 750 ps | | | | | | | | | | |
| Setup and hold violation detector (normal synchronous clock mode) | <p>Any channel can be enabled to detect a setup or hold violation. The range is from 8.0 ns before the clock edge to 8.0 ns after the clock edge in 0.125 ns steps. The channel setup and hold violation size can be individually programmed.</p> <p>The range can be shifted towards the positive region by 0 ns, 4 ns, or 8 ns. With a 0 ns shift, the range is +8 ns to -8 ns; with a 4 ns shift, the range is +12 ns to -4 ns; with an 8 ns shift, the range is +16 ns to 0 ns. The sample point selection region is the same as the setup and hold window.</p> <p>Any setup value is subject to variation of up to the channel skew specification. Any hold value is subject to variation of up to the channel skew specification.</p> | | | | | | | | | | |
| Transition detector | <p>16 transition detectors.</p> <p>Any channel group can be enabled or disabled to detect a rising transition, a falling transition, or both rising and falling transitions between the current valid data sample and the previous valid data sample.</p> | | | | | | | | | | |
| Counter/timers | <p>2 counter/timers, 51 bits wide, can be clocked up to 500 MHz</p> <p>Maximum count is $2^{50}-1$ (excluding sign bit)</p> <p>Maximum time is 4.5×10^6 seconds or 52 days</p> <p>Counters can be used as settable, resettable, and testable flags. Counters can be reset, do nothing, increased, or decreased. Timers can be reset, started, stopped, or not changed. Counters and timers have zero reset latency and one clock terminal count latency.</p> | | | | | | | | | | |
| Signal In 1 | A backplane input signal. | | | | | | | | | | |

Table 65: TLA7Axx module trigger system (Cont.)

| Characteristic | Description |
|---------------------------------------|--|
| Signal In 2 | A backplane input signal. |
| Trigger In | A backplane input signal that causes the main acquisition and the MagniVu acquisition to trigger if they are not already triggered. |
| Active trigger resources | 16 maximum (excluding counter/timers) Word recognizers are traded off one-for-one as Signal In 1, Signal In 2, glitch detection, setup and hold detection, or transition detection resources are added. |
| Trigger states | 16 |
| ✓ Trigger state sequence rate | Same rate as valid data samples received. 500 MHz maximum. |
| Trigger machine actions | |
| Main acquisition trigger | Triggers the main acquisition memory |
| Main trigger position | Programmable to any data sample (2 ns boundaries) |
| MagniVu trigger | Main acquisition machine controls the triggering of the MagniVu memory |
| MagniVu trigger position | Programmable within 2 ns boundaries and separate from the main acquisition memory trigger position |
| Increment/decrement counter | Counter/timers used as counters can be incremented or decremented. |
| Start/stop timer | Either of the two counter/timers used as timers can be started or stopped. |
| Reset counter/timer | Either of the two counter/timers can be reset. When a counter/timer used as a timer is reset, the timer continues in the started or stopped state that it was prior to the reset. |
| Reloadable word recognizer (snapshot) | Loads the current acquired data sample into the reference value of the word recognizer via a trigger machine action. All data channels are loaded into their respective word recognizer reference register on a one-to-one manner. |
| Reloadable word recognizer latency | 378 ns |
| Signal Out | A signal sent to the backplane to be used by other modules |
| Trigger Out | A signal sent to the backplane to trigger other modules |
| Storage control | |
| Storage | Storage is allowed only if a specific condition is met. The condition can use any of the trigger resources except for counter/timers. Storage commands defined in the current trigger state will override the global storage control. Storage can be used to start the acquisition with storage initially turned on (default setting) or off. |
| By event | Storage can be turned on or off; only the current sample can be stored. Event storage control overrides any global storage commands. |
| Block storage (store stretch) | When enabled, 31 samples are stored before and after the valid sample. This allows the storage of a group of samples around a valid data sample when storage control is being used. This only has meaning when storage control is used. Block storage is disallowed when glitch storage or setup and hold violation storage is enabled. |

Table 65: TLA7Axx module trigger system (Cont.)

| Characteristic | Description |
|----------------------------------|--|
| Glitch violation storage | Glitch violation information can be stored to acquisition memory with each data sample when asynchronous clocking is used. The acquisition data storage size is reduced by half when this mode is enabled (the other half holds violation information). The fastest asynchronous clock rate is reduced to 4 ns. |
| Setup and hold violation storage | Setup and hold violation information can be stored to acquisition memory with each data sample when synchronous clocking is used. The acquisition data storage size is reduced by half when this mode is enabled (the other half holds violation information). The maximum synchronous clock rate in this mode is 235 MHz. |

Table 66: MagniVu acquisition

| Characteristic | Description |
|-------------------------|---|
| MagniVu sampling period | Data is asynchronously sampled and stored every 125 ps in a separate MagniVu (high-resolution) memory. The storage speed can be changed by software to 250 ps, 500 ps, or 1000 ps with no loss in memory depth so that the high resolution memory covers more time at a lower resolution. |
| MagniVu memory depth | Approximately 16 K per channel. The MagniVu memory is separate from the main acquisition memory. |

Table 67: Merged modules

| Characteristic | Description |
|--|--|
| Number of merged modules | 2, 3, 4, or 5 adjacent modules can be merged. Only 102-channel modules or 136-channel modules can be merged. Merged modules can have unequal channel widths and channel depths. |
| Number of channels after merging | The sum of all channels available on each of the merged modules including clocks and qualifiers. No channels are lost when modules are merged. |
| Merged system acquisition depth | Channel depth is equal to that of the shallowest module. |
| Number of clock and qualifier channels after merging | The qualifier channels on the slave modules can only be used as data channels. They cannot influence the actual clocking function of the logic analyzer (for example, log strobe generation). The clock channels on the slave TLA7Axx modules can capture data on those modules for source-synchronous applications. Each slave module contributes four additional clock channels to the merged set. All clock and qualifier channels are stored to acquisition memory. |

Table 67: Merged modules (Cont.)

| Characteristic | Description |
|---------------------------------|--|
| Merged system trigger resources | The same as a single module except for word recognizer width, setup and hold violation detector width, glitch detector width, and transition detector width has increased to equal that of the merged channel width. Range recognizers will increase to the merged channel width up to three modules; range recognition is not supported on the two outside slave modules. |
| Merged range significance | Most significant Master, Slave 1, Slave 2 |

Table 68: Data handling

| Characteristic | Description |
|--|--|
| Nonvolatile memory retention time (<i>Typical</i>) | The battery life is integral to the NVRAM; battery life is > 10 years. |

Table 69: Mechanical

| Characteristic | Description |
|---------------------|--|
| Material | Chassis parts are constructed of aluminum alloy. The front panel is constructed of plastic laminated to steel front panel. Circuit boards are constructed of glass laminate. |
| Weight | |
| 136-channel module | 5 lb 6 oz. (2.438 kg) |
| 102-channel module | 5 lb 4 oz. (2.381 kg) |
| 68-channel module | 5 lb 0.5 oz. (2.282 kg) |
| 34-channel module | 4 lb 15.5 oz. (2.254 kg) |
| Shipping weight | 7 lb 12 oz. (3.515 kg) for 136-channel module when packaged for domestic shipment |
| Overall dimensions | |
| Height | 10.32 in (262 mm) |
| Width | 2.39 in (61 mm) with merge connector in the recessed position Width increases by 0.41 in (10.41 mm) with merge connector in the extended position |
| Length | 14.7 in (373 mm) |
| Mainframe interlock | 1.4 ECL keying is implemented |

TLA7Lx/Mx/Nx/Px/Qx Module Characteristics

Tables 70 through 76 list the specifications of the TLALx/Mx/Nx/Px/Qx logic analyzer modules.

Table 70: LA module channel width and depth

| Characteristic | Description | |
|--------------------------|--|--|
| Number of channels | Product | Channels |
| | TLA7N1, TLA7L1, TLA7M1 | 32 data and 2 clock |
| | TLA7N2, TLA7P2, TLA7Q2, TLA7L2, TLA7M2 | 64 data and 4 clock |
| | TLA7N3, TLA7L3, TLA7M3 | 96 data, 4 clock, and 2 qualifier |
| | TLA7N4, TLA7P4, TLA7Q4, TLA7L4, TLA7M4 | 128 data, 4 clock, and 4 qualifier |
| Acquisition memory depth | Product | Memory depth |
| | TLA7L1, TLA7L2, TLA7L3, TLA7L4 | 32 K or 128 K samples ¹ |
| | TLA7M1, TLA7M2, TLA7M3, TLA7M4 | 512 K samples |
| | TLA7N1, TLA7N2, TLA7N3, TLA7N4 | 64 K or 256 K or 1 M or 4 M samples ¹ |
| | TLA7P2, TLA7P4 | 16 M samples |
| | TLA7Q2, TLAQP4 | 64 M samples |

¹ PowerFlex options

Table 71: LA module clocking

| Characteristic | Description | |
|---|--|----------------|
| Asynchronous clocking | | |
| ✓ Internal sampling period ¹ | 4 ns to 50 ms in a 1-2-5 sequence 2 ns in 2x Clocking mode | |
| ✓ Minimum recognizable word ² (across all channels) | Channel-to-channel skew + sample uncertainty Example: for a P6417 or a P6418 Probe and a 4 ns sample period = 1.6 ns + 4 ns = 5.6 ns | |
| Synchronous clocking | | |
| Number of clock channels ³ | Product | Clock channels |
| | TLA7N1, TLA7L1, TLA7M1 | 2 |
| | TLA7N2, TLA7P2, TLA7Q2, TLA7L2, TLA7M2 | 4 |
| | TLA7N3, TLA7L3, TLA7M3 | 4 |
| | TLA7N4, TLA7P4, TLA7Q4, TLA7L4, TLA7M4 | 4 |

Table 71: LA module clocking (Cont.)

| Characteristic | Description |
|---|--|
| Number of qualifier channels | Product |
| | TLA7N1, TLA7L1, TLA7M1 |
| | TLA7N2, TLA7P2, TLA7Q2, TLA7L2, TLA7M2 |
| | TLA7N3, TLA7L3, TLA7M3 |
| | Qualifier channels |
| | 0 |
| | 0 |
| | 2 |
| | 4 |
| ✓ Setup and hold window size (data and qualifiers) | <p>Maximum window size = Maximum channel-to-channel skew + (2 x sample uncertainty) + 0.4 ns</p> <p>Maximum setup time = User interface setup time + 0.8 ns</p> <p>Maximum hold time = User interface hold time + 0.2 ns</p> <p>Maximum setup time for slave module of merged pair = User Interface setup time + 0.8 ns</p> <p>Maximum hold time for slave module of merged pair = User Interface hold time + 0.7 ns</p> <p>Examples: for a P6417, P6418, or P6434 probe and user interface setup and hold of 2.0/0.0 typical:</p> <p>Maximum window size = 1.6 ns + (2 x 500 ps) + 0.4ns = 3.0 ns</p> <p>Maximum setup time = 2.0 ns + 0.8 ns = 2.8 ns</p> <p>Maximum hold time = 0.0 ns + 0.2 ns = 0.2ns</p> |
| Setup and hold window size (data and qualifiers) (Typical) | <p>Channel-to-channel skew (<i>typical</i>) + (2 x sample uncertainty)</p> <p>Example: for P6417 or P6418 Probe = 1 ns + (2 x 500 ps) = 2 ns</p> |
| Setup and hold window range | <p>For the TLA7Nx/Px/Qx logic analyzer modules, each channel of the setup and hold window can be moved from +8.5 ns (Ts) to -7.0 ns (Ts) in 0.5 ns steps (setup time). Hold time follows the setup time by the setup and hold window size.</p> <p>For the TLA7Lx and TLAMx logic analyzer modules, the user interface restricts the setup and hold window range to groups rather than individual channels.</p> |
| ✓ Maximum synchronous clock rate ⁴ | <p>200 MHz in full speed mode (5 ns minimum between active clock edges)</p> <p>100 MHz in half speed mode (10 ns minimum between active clock edges)</p> |
| Demux clocking | |
| Demux Channels TLA7N3, TLA7N4, TLA7P4, TLA7Q4, TLA 7L3, TLA 7L4, TLA 7M3, TLA 7M4 | <p>Channels multiplex as follows:</p> <p>A3(7:0) to D3(7:0)</p> <p>A2(7:0) to D2(7:0)</p> <p>A1(7:0) to D1(7:0)</p> <p>A0(7:0) to D0(7:0)</p> |
| TLA7N1, TLA7N2, TLA7P2, TLA7Q2, TLA 7L1, TLA 7L2, TLA 7M1, TLA 7M2 | <p>Channels multiplex as follows:</p> <p>A3(7:0) to C3(7:0)</p> <p>A2(7:0) to C2(7:0)</p> <p>A1(7:0) to D1(7:0) TLA7N2, TLA7P2, TLA7Q2, TLA 7L2, TLA 7M2 only</p> <p>A0(7:0) to D0(7:0) TLA7N2, TLA7P2, TLA7Q2, TLA 7L2, TLA 7M2 only</p> |
| Time between DeMux clock edges ⁴ (Typical) | <p>5 ns minimum between DeMux clock edges in full-speed mode</p> <p>10 ns minimum between DeMux clock edges in half-speed mode</p> |

Table 71: LA module clocking (Cont.)

| Characteristic | Description |
|--|--|
| Time between DeMux store clock edges ⁴ (Typical) | 10 ns minimum between DeMux master clock edges in full-speed mode 20 ns minimum between DeMux master clock edges in half-speed mode |
| Data Rate (Typical) TLA7N1, TLA7N2, TLA7P2, TLA7Q2, TLA7N3, TLA7N4, TLA7P4, TLA7Q4, | 400 MHz (200 MHz option required) half channel. (Requires channels to be multiplexed.) These multiplexed channels double the memory depth. |
| Clocking state machine | |
| Pipeline delays | For the TLA7Nx/Px/Qx logic analyzer modules, each channel can be programmed with a pipeline delay of 0 through 3 active clock edges. For the TLA7Lx and TLAMx logic analyzer modules, the user interface restricts the programming to groups rather than individual channels. |
| <p>¹ It is possible to use storage control and only store data when it has changed (transitional storage).</p> <p>² Applies to asynchronous clocking only. Setup and hold window specification applies to synchronous clocking only.</p> <p>³ Any or all of the clock channels may be enabled. For an enabled clock channel, the rising edge, falling edge, or both edges can be selected as the active clock edges. The clock channels are stored.</p> <p>⁴ Full and half speed modes are controlled by PowerFlex options and upgrade kits.</p> | |

Table 72: LA module trigger system

| Characteristic | Description | | | | | | | | | | |
|--------------------------------|--|---------------------|---------------------|---------------------|--------------------|---------------------|---------------------|--------------------|---------------------|--------------------|---------------------|
| Triggering Resources | | | | | | | | | | | |
| Word/Range recognizers | 16 word recognizers. The word recognizers can be combined to form full width, double bounded, range recognizers. The following selections are available: <table border="0"> <tr> <td>16 word recognizers</td> <td>0 range recognizers</td> </tr> <tr> <td>13 word recognizers</td> <td>1 range recognizer</td> </tr> <tr> <td>10 word recognizers</td> <td>2 range recognizers</td> </tr> <tr> <td>7 word recognizers</td> <td>3 range recognizers</td> </tr> <tr> <td>4 word recognizers</td> <td>4 range recognizers</td> </tr> </table> | 16 word recognizers | 0 range recognizers | 13 word recognizers | 1 range recognizer | 10 word recognizers | 2 range recognizers | 7 word recognizers | 3 range recognizers | 4 word recognizers | 4 range recognizers |
| 16 word recognizers | 0 range recognizers | | | | | | | | | | |
| 13 word recognizers | 1 range recognizer | | | | | | | | | | |
| 10 word recognizers | 2 range recognizers | | | | | | | | | | |
| 7 word recognizers | 3 range recognizers | | | | | | | | | | |
| 4 word recognizers | 4 range recognizers | | | | | | | | | | |
| Range recognizer channel order | From most-significant probe group to least-significant probe group: C3 C2 C1 C0 E3 E2 E1 E0 A3 A2 D3 D2 A1 A0 D1 D0 Q3 Q2 Q1 Q0 CK3 CK2 CK1 CK0 Missing channels for modules with fewer than 136 channels are omitted. When merged, the range recognition extends across all the modules; the master module contains the most-significant groups. The master module is to the left (lower-numbered slot) of a merged pair. The master module is in the center when three modules are merged. Slave module 1 is located to the right of the master module, and slave module 2 is located to the left of the master module. | | | | | | | | | | |
| Glitch detector ^{1,2} | Each channel group can be enabled to detect a glitch | | | | | | | | | | |

Table 72: LA module trigger system (Cont.)

| Characteristic | Description |
|--|---|
| Minimum detectable glitch pulse width (Typical) | 2.0 ns (single channel with a P6417, P6418, or P6434 probe) |
| Setup and hold violation detector ^{1,3} | Each channel can be enabled to detect a setup and hold violation. The range is from 8 ns before the clock edge to 8 ns after the clock edge. The range can be selected in 0.5 ns increments. For the TLA7Lx and TLAMx logic analyzer modules, the user interface restricts the setup and hold violation detector to groups rather than individual channels. The setup and hold violation of each window can be individually programmed. |
| Transition detector ^{1, 4} | Each channel group can be enabled or disabled to detect a transition between the current valid data sample and the previous valid data sample. |
| Counter/Timers | 2 counter/timers, 51 bits wide, can be clocked up to 250 MHz. Maximum count is 2^{51} . Maximum time is 9.007×10^6 seconds or 104 days. Counters and timers can be set, reset, or tested and have zero reset latency. |
| Signal In 1 | A backplane input signal |
| Signal In 2 | A backplane input signal |
| Trigger In | A backplane input signal that causes the main acquisition and the MagniVu™ acquisition to trigger if they are not already triggered |
| Active trigger resources | 16 maximum (excluding counter/timers) Word recognizers are traded off one-by-one as Signal In 1, Signal In 2, glitch detection, setup and hold detection, or transition detection resources are added. |
| Trigger States | 16 |
| ✓ Trigger State sequence rate | Same rate as valid data samples received, 250 MHz maximum |
| Trigger Machine Actions | |
| Main acquisition trigger | Triggers the main acquisition memory |
| Main trigger position | Trigger position is programmable to any data sample (4 ns boundaries) |
| Increment counter | Either of the two counter/timers used as counters can be increased. |
| Start/Stop timer | Either of the two counter/timers used as timers can be started or stopped. |
| Reset counter/timer | Either of the two counter/timers can be reset. When a counter/timer is used as a timer and is reset, the timer continues in the started or stopped state that it was in prior to the reset. |
| Signal out | A signal sent to the backplane to be used by other modules |
| Trigger out | A trigger out signal sent to the backplane to trigger other modules |

Table 72: LA module trigger system (Cont.)

| Characteristic | Description |
|--------------------------|---|
| Storage Control | |
| Global storage | Storage is allowed only when a specific condition is met. This condition can use any of the trigger machine resources except for the counter/timers. Storage commands defined in the current trigger state will override the global storage control. Global storage can be used to start the acquisition with storage initially turned on (default) or turned off. |
| By event | Storage can be turned on or off; only the current sample can be stored. The event storage control overrides any global storage commands. |
| Block storage | When enabled, 31 samples are stored before and after the valid sample. Block storage is disallowed when glitch storage or setup and hold violation is enabled. |
| Glitch violation storage | The acquisition memory can be enabled to store glitch violation information with each data sample when asynchronous clocking is used. The probe data storage size is reduced by one half (the other half holds the violation information). The fastest asynchronous clocking rate is reduced to 10 ns. |

- 1 **Each use of a glitch detector, setup and hold violation detector, or transition detector requires a trade-off of one word recognizer resource.**
- 2 **Any glitch is subject to pulse width variation of up to the channel-to-channel skew specification + 0.5 ns.**
- 3 **For TLA7N1, TLA7N2, TLA7N3, TLA7N4, TLA7P2, TLA7P4, TLA7Q2, and TLA7Q4 Logic Analyzer modules, any setup value is subject to variation of up to 1.8 ns; any hold value is subject to variation of up to 1.2 ns. For TLA7L1, TLA7L2, TLA7L3, TLA7L4, TLA7M1, TLA7M2, TLA7M3, and TLA7M4 Logic Analyzer modules, any setup value is subject to variation of up to 1.6 ns; any hold value is subject to variation of up to 1.4 ns.**
- 4 **This mode can be used to create transitional storage selections where all channels are enabled.**

Table 73: LA module MagniVu™ feature

| Characteristic | Description |
|--------------------------|--|
| MagniVu™ memory depth | 2016 samples per channel |
| MagniVu™ sampling period | Data is asynchronously sampled and stored every 500 ps in a separate high resolution memory. |

Table 74: LA module data handling

| Characteristic | Description |
|---|---|
| Nonvolatile memory retention time (Typical) | Battery is integral to the NVRAM. Battery life is > 10 years. |

Table 75: LA module input parameters with probes

| Characteristic | Description |
|--|--|
| ✓ Threshold Accuracy | ±100 mV |
| Threshold range and step size | Settable from +5 V to -2 V in 50 mV steps |
| Threshold channel selection | 16 threshold groups assigned to channels. P6417 and P6418 probes have two threshold settings, one for the clock/qualifier channel and one for the data channels. P6434 probes have four threshold settings, one for each of the clock/qualifier channels and two for the data channels (one per 16 data channels). |
| ✓ Channel-to-channel skew | ≤ 1.6 ns maximum (When merged, add 0.5 ns for the slave module.) |
| Channel-to-channel skew (Typical) | ≤ 1.0 ns typical (When merged, add 0.3 ns for the slave module.) |
| Sample uncertainty | |
| Asynchronous: | Sample period |
| Synchronous: | 500 ps |
| Probe input resistance (Typical) | 20 kΩ |
| Probe input capacitance: P6417, P6434 (Typical) | 2 pF |
| Probe input capacitance: P6418 (Typical) | 1.4 pF data channels 2 pF CLK/Qual channels |
| Minimum slew rate (Typical) | 0.2 V/ns |
| Maximum operating signal | 6.5 V _{p-p} -3.5 V absolute input voltage minimum 6.5 V absolute input voltage maximum |
| Probe overdrive: P6417, P6418 P6434 | ±250 mV or ±25% of signal swing minimum required beyond threshold, whichever is greater ±300 mV or ±25% of signal swing minimum required beyond threshold, whichever is greater ±4 V maximum beyond threshold |
| Maximum nondestructive input signal to probe | ±15 V |
| Minimum input pulse width signal (single channel) (Typical) | 2 ns |
| Delay time from probe tip to input probe connector (Typical) | 7.33 ns |

Table 76: LA module mechanical

| Characteristic | Description |
|-----------------------|--|
| Slot width | Requires 2 mainframe slots |
| Weight (Typical) | 5 lbs 10 oz. (2.55 kg) for TLA7N4 and TLA7P4 8 lbs (3.63 kg) for TLA7N4 and TLA7P4 packaged for domestic shipping |
| Overall dimensions | |
| Height | 262 mm (10.32 in) |
| Width | 61 mm (2.39 in) |
| Depth | 373 mm (14.7 in) |
| Probe cables | |
| P6417 length | 1.8 m (6 ft) |
| P6418 length | 1.93 m (6 ft 4 in) |
| P6434 length | 1.6 m (5 ft 2 in) |
| Mainframe interlock | 1.4 ECL keying is implemented |

DSO Module Characteristics

Tables 77 through 81 list the specifications for the DSO Module.

Table 77: DSO module signal acquisition system

| Characteristic | Description | | |
|--|--|--|--------------------------|
| ✓ Accuracy, DC gain | ±1.5% for full scale ranges from 20 mV to 100 V ±2.0% for full scale ranges <19.9 mV | | |
| ✓ Accuracy, internal offset ¹ | <i>Full scale range setting</i> | <i>Offset accuracy</i> | |
| | 10 mV - 1 V | ±[(0.2% × offset) + 1.5 mV + (6% × full scale range)] | |
| | 1.01 V - 10 V | ±[(0.25% × offset) + 15 mV + (6% × full scale range)] | |
| | 10.1 V - 100 V | ±[(0.25% × offset) + 150 mV + (6% × full scale range)] | |
| ✓ Analog bandwidth, DC-50 Ω coupled | <i>Full scale range setting</i> | <i>Bandwidth²</i> | |
| | 10.1 V - 100 V | DC - 500 MHz (TLA7E1 and TLA7E2) DC - 500 MHz (TLA7D1 and TLA7D2) | |
| | 100 mV - 10 V | DC - 1 GHz (TLA7E1 and TLA7E2) DC - 500 MHz (TLA7D1 and TLA7D2) | |
| | 50 mV - 99.5 mV | DC - 750 MHz (TLA7E1 and TLA7E2) DC - 500 MHz (TLA7D1 and TLA7D2) | |
| | 20 mV - 49.8 mV | DC - 600 MHz (TLA7E1 and TLA7E2) DC - 500 MHz (TLA7D1 and TLA7D2) | |
| | 10 mV - 19.9 mV | DC - 500 MHz (TLA7E1 and TLA7E2) DC - 500 MHz (TLA7D1 and TLA7D2) | |
| Bandwidth, analog, selections | 20 MHz, 250 MHz, and FULL on each channel | | |
| Calculated rise time (Typical) ³ Typical full-bandwidth rise times are shown in the chart to the right | <i>Full scale range setting</i> | <i>TLA7E1 and TLA7E2</i> | <i>TLA7D1 and TLA7D2</i> |
| | 10.1 V - 100 V | 900 ps | 900 ps |
| | 100 mV - 10 V | 450 ps | 900 ps |
| | 50 mV - 99.5 mV | 600 ps | 900 ps |
| | 20 mV - 49.8 mV | 750 ps | 900 ps |
| | 10 mV - 19.9 mV | 900 ps | 900 ps |
| Crosstalk (channel isolation) | ≥300:1 at 100 MHz and ≥100:1 at the rated bandwidth for the channel's sensitivity (Full Scale Range) setting, for any two channels having equal sensitivity settings | | |
| Digitized bits | 8 | | |

Table 77: DSO module signal acquisition system (Cont.)

| Characteristic | Description | | |
|--|--|---|--|
| Effective bits, real time sampling (Typical) | <i>Input frequency</i> | <i>TLA7E1 and TLA7E2 5 GS/s (each channel)</i> | <i>TLA7D1 and TLA7D2 2.5 GS/s (each channel)</i> |
| | 10.2 MHz | 6.2 bits | 6.2 bits |
| | 98 MHz | 6.1 bits | 6.1 bits |
| | 245 MHz | 6.0 bits | 6.0 bits |
| | 490 MHz | 5.7 bits | 5.7 bits |
| | 990 MHz | 5.2 bits | N/A |
| Frequency limit, upper, 20 MHz bandwidth limited (Typical) | 20 MHz | | |
| Frequency limit, upper, 250 MHz bandwidth limited (Typical) | 250 MHz | | |
| Input channels | <i>Product</i> | <i>Channels</i> | |
| | TLA7E2 | Four | |
| | TLA7D2 | Four | |
| | TLA7E1 | Two | |
| | TLA7D1 | Two | |
| Input coupling | DC, AC, or GND ⁴ | | |
| Input impedance, DC-1 M Ω coupled | 1 M Ω \pm 0.5% in parallel with 10 pF \pm 3 pF | | |
| Input impedance selections | 1 M Ω or 50 Ω | | |
| Input resistance, DC-50 Ω coupled | 50 Ω \pm 1% | | |
| Input VSWR, DC-50 Ω coupled | \leq 1.3:1 from DC - 500 MHz, \leq 1.5:1 from 500 MHz - 1 GHz | | |
| Input voltage, maximum, DC-1 M Ω , AC-1 M Ω , or GND coupled | 300 V _{RMS} but no greater than \pm 420 V peak, Installation category II, derated at 20 dB/decade above 1 MHz | | |
| Input voltage, maximum, DC-50 Ω or AC-50 Ω Coupled | 5 V _{RMS} , with peaks \leq \pm 25 V | | |
| Lower frequency limit, AC coupled (Typical) | \leq 10 Hz when AC-1 M Ω Coupled; \leq 200 kHz when AC-50 Ω Coupled ⁵ | | |
| ✓ Random noise | <i>Bandwidth selection</i> | <i>RMS noise</i> | |
| | Full | \leq (350 μ V + 0.5% of the full scale Setting) | |
| | 250 MHz | \leq (165 μ V + 0.5% of the full scale Setting) | |
| | 20 MHz | \leq (75 μ V + 0.5% of the full scale Setting) | |

Table 77: DSO module signal acquisition system (Cont.)

| Characteristic | Description | | |
|---|---------------------------------|------------------------|--------------------------------------|
| Range, internal offset | <i>Full scale range setting</i> | | <i>Offset range</i> |
| | 10 mV - 1 V | | ±1 V |
| | 1.01 V - 10 V | | ±10 V |
| | 10.1 V - 100 V | | ±100 V |
| Range, sensitivity (full scale range), all channels | 10 mV to 100 V ⁶ | | |
| Step response settling errors (Typical) ^{7, 8} | <i>Full scale range setting</i> | <i>± Step response</i> | <i>Maximum settling error (%) at</i> |
| | | | <i>20 ns 100 ns 20 ms</i> |
| | 10 mV - 1 V | ≤2 V | 0.5% 0.2% 0.1% |
| | 1.01 V - 10 V | ≤20 V | 1.0% 0.5% 0.2% |
| | 10.1 V - 100 V | ≤200 V | 1.0% 0.5% 0.2% |

¹ Net offset is the nominal voltage level at the digitizing oscilloscope input that corresponds to the center of the A/D Converter dynamic range. Offset accuracy is the accuracy of this voltage level.

² The limits given are for the ambient temperature range of 0 °C to +30 °C. Reduce the upper bandwidth frequencies by 5 MHz for each °C above +30 °C. The bandwidth must be set to FULL.

³ Rise time (rounded to the nearest 50 ps) is calculated from the bandwidth when Full Bandwidth is selected. It is defined by the following formula:

$$\text{Rise Time (ns)} = 450 \div \text{BW (MHz)}$$

⁴ GND input coupling disconnects the input connector from the attenuator and connects a ground reference to the input of the attenuator.

⁵ The AC Coupled Lower Frequency Limits are reduced by a factor of 10 when 10X passive probes are used.

⁶ The sensitivity ranges from 10 mV to 100 V full scale in a 1-2-5 sequence of coarse settings. Between coarse settings, you can adjust the sensitivity with a resolution equal to 1% of the more sensitive coarse setting. For example, between the 500 mV and 1 V ranges, the sensitivity can be set with 5 mV resolution.

⁷ The Full Bandwidth settling errors are typically less than the percentages from the table.

⁸ The maximum absolute difference between the value at the end of a specified time interval after the mid-level crossing of the step, and the value one second after the mid-level crossing of the step, expressed as a percentage of the step amplitude. See IEEE std. 1057, Section 4.8.1, *Settling Time Parameters*.

Table 78: DSO module timebase system

| Characteristic | Description | |
|--|--|--|
| Range, Extended Realtime Sampling Rate | 5 S/s to 10 MS/s in a 1-2.5-5 sequence | |
| Range, Realtime Sampling Rate | <i>Products</i> | <i>Limits</i> |
| | TLA7E1 and TLA7E2 | 25 MS/s to 5 GS/s on all channels simultaneously in a 1-2.5-5 sequence |
| | TLA7D1 and TLA7D2 | 25 MS/s to 2.5 GS/s on all channels simultaneously in a 1-2.5-5 sequence |
| Record Length | 512, 1024, 2048, 4096, 8192, and 15000 | |
| ✓ Long Term Sample Rate | ±100 ppm over any ≥ 1 ms interval | |

Table 79: DSO module trigger system

| Characteristic | Description | |
|---|---|--------------------------------|
| ✓ Accuracy (Time) for Pulse Glitch or Pulse Width Triggering | <i>Time Range</i> | <i>Accuracy</i> |
| | 2 ns to 500 ns | ±(20% of Setting + 0.5 ns) |
| | 520 ns to 1 s | ±(104.5 ns + 0.01% of Setting) |
| ✓ Accuracy (DC) for Edge Trigger Level, DC Coupled | ±((2% × Setting) + 0.03 of Full Scale Range + Offset Accuracy) for signals having rise and fall times ≥20 ns | |
| Range (Time) for Pulse Glitch and Pulse Width Triggering | 2 ns to 1 s | |
| Range, Trigger Level | <i>Source</i> | <i>Range</i> |
| | Any Channel | ±100% of full scale range |
| Range, Trigger Point Position | Minimum: 0% Maximum: 100% | |
| Resolution, Trigger Level | 0.2% of full scale for any Channel source | |
| Resolution, Trigger Position | One Sample Interval at any Sample Rate | |
| Sensitivities, Pulse-Type Runt Trigger (<i>Typical</i>) | 10% of full scale, from DC to 500 MHz, for vertical settings >100 mV full scale and ≤10 V full scale at the BNC input | |
| Sensitivities, Pulse-Type Trigger Width and Glitch (<i>Typical</i>) | 10% of full scale for vertical settings >100 mV full scale and ≤10 V full scale at the BNC input | |

Table 79: DSO module trigger system (Cont.)

| Characteristic | Description | | |
|--|---|--|--|
| ✓ Sensitivity, Edge-Type Trigger, DC Coupled | The minimum signal levels required for stable edge triggering of an acquisition when the trigger source is DC-coupled | | |
| | <i>Products</i> | <i>Trigger Source</i> | <i>Sensitivity</i> |
| | TLA7E1 and TLA7E2 | Any Channel | 3.5% of Full Scale Range from DC to 50 MHz, increasing to 10% of Full Scale Range at 1 GHz |
| | TLA7D1 and TLA7D2 | Any Channel | 3.5% of Full Scale Range from DC to 50 MHz, increasing to 10% of Full Scale Range at 500 MHz |
| Sensitivity, Edge-Type Trigger, Not DC Coupled (Typical) | <i>Trigger Coupling</i> | <i>Typical Signal Level for Stable Triggering</i> | |
| | AC | Same as the DC-coupled limits for frequencies above 60 Hz; attenuates signals below 60 Hz | |
| | High Frequency Reject | One and one-half times the DC-coupled limits from DC to 30 kHz; attenuates signals above 30 kHz | |
| | Low Frequency Reject | One and one-half times the DC-coupled limits for frequencies above 80 kHz; attenuates signals below 80 kHz | |
| | Noise Reject | Three times the DC-coupled limits | |
| Time, Minimum Pulse or Rearm, and Minimum Transition Time, for Pulse-Type Triggering (Typical) | For vertical settings >100 mV and ≤10 V at the BNC input | | |
| | <i>Pulse Class</i> | <i>Minimum Pulse Width</i> | <i>Minimum Rearm Width</i> |
| | Glitch | 1 ns | 2 ns + 5% of Glitch Width Setting |
| | Width | 1 ns | 2 ns + 5% of Width Upper Limit Setting |
| Trigger Position Error, Edge Triggering (Typical) | <i>Acquisition Mode</i> | <i>Trigger Position Error</i> ¹ | |
| | Sample | ±(1 Sample Interval + 1 ns) | |

¹ The trigger position errors are typically less than the values given here. These values are for triggering signals having a slew rate at the trigger point of ≥5% of full scale/ns.

Table 80: DSO module front-panel connectors

| Characteristic | Description |
|---|--|
| ✓ Probe Compensator, Output Voltage The Probe Compensator output voltage in peak-to-peak Volts | 0.5 V (base-top) ± 1% into a ≥ 50 Ω load |

Table 81: DSO module mechanical

| Characteristic | Description | |
|------------------------------|--|--------------------|
| Slot width | Requires 2 mainframe slots | |
| Weight (Typical) | <i>Products</i> | <i>Weight</i> |
| | TLA7D1 and TLA7E1 | 2.44 kg (5.38 lbs) |
| | TLA7D2 and TLA7E2 | 2.55 kg (5.63 lbs) |
| Shipping Weight (Typical) | <i>Products</i> | <i>Weight</i> |
| | TLA7D1 and TLA7E1 | 6.35 kg (14 lbs) |
| | TLA7D2 and TLA7E2 | 7.71 kg (17 lbs) |
| Overall Dimensions | Height: 262.05 mm (10.32 in) Width: 60.66 mm (2.39 in) Depth: 373.38 mm (14.70 in) | |

External Oscilloscope (iView) Characteristics

Table 82 lists the characteristics for iView (Integrated View) and for the Tektronix logic analyzer when connected to an external oscilloscope. For detailed information on the individual specifications of the external oscilloscope, refer to the documentation that accompanies the oscilloscope.

Table 82: External oscilloscope (Integrated View or iView) characteristics

| Characteristic | Description |
|---|---|
| Supported Tektronix logic analyzer instruments | TLA600 series, TLA714, TLA715 TLA720, TLA721 |
| TLA application software version | V4.2 or greater |
| Minimum recommended TLA controller DRAM ¹ | 256 MB |
| Supported external oscilloscopes <i>(for the latest list of supported external oscilloscopes, visit our website at www.tektronix.com/la)</i> | TDS1002, TDS1012, TDS2002, TDS2012, TDS214, TDS2022, TDS2024 TDS3012, TDS3014, TDS3032, TDS3034, TDS3052, TDS3054 (TDS3GM GPIB/RS232 communication module required) TDS3012B, TDS3014B, TDS3032B, TDS3034B, TDS3052B, TDS3054B TDS5032, TDS5034, TDS5052, TDS5054, TDS5104 TDS6404, TDS6604 TDS7054, TDS7104, TDS7154, TDS7254, TDS7404 CSA7154, CSA7404 TDS654C, TDS684C, TDS694C TDS724C, TDS754C, TDS784C, TDS724D, TDS754D, TDS784D, TDS794D |
| External oscilloscope software or firmware version number | |
| TDS684C, TDS694C | Any version |
| TDS3000 series | Any version |
| TDS5000 series | Any version |
| TDS6000 series | Any version |
| TDS7000, CSA7000 series | Version 1.2 or greater |
| Maximum number of external oscilloscopes | One per Tektronix logic analyzer |
| iView cable length | 6.56 ft (2 m) |

Table 82: External oscilloscope (Integrated View or iView) characteristics (Cont.)

| Characteristic | Description |
|--|-------------|
| Time correlation uncertainty ² (<i>Typical at system trigger</i>) | |
| Logic analyzer triggers external oscilloscope (2 ns + logic analyzer sample period + external oscilloscope sample period) | 3 ns |
| External oscilloscope triggers logic analyzer (4 ns + logic analyzer sample period + external oscilloscope sample period) | 5 ns |

¹ **If DRAM is less than 256 MB, the record length of the external oscilloscope may be limited to 1 M.**

² **Includes sampling uncertainty, typical jitter, slot-to-slot skew, and probe-to-probe variations to provide a *typical* number for the measurement.**